

ANGLEmaster LASER

High resolution profile laser sensor

CUTTING ANGLE measurements faster, more comfortably & consistently

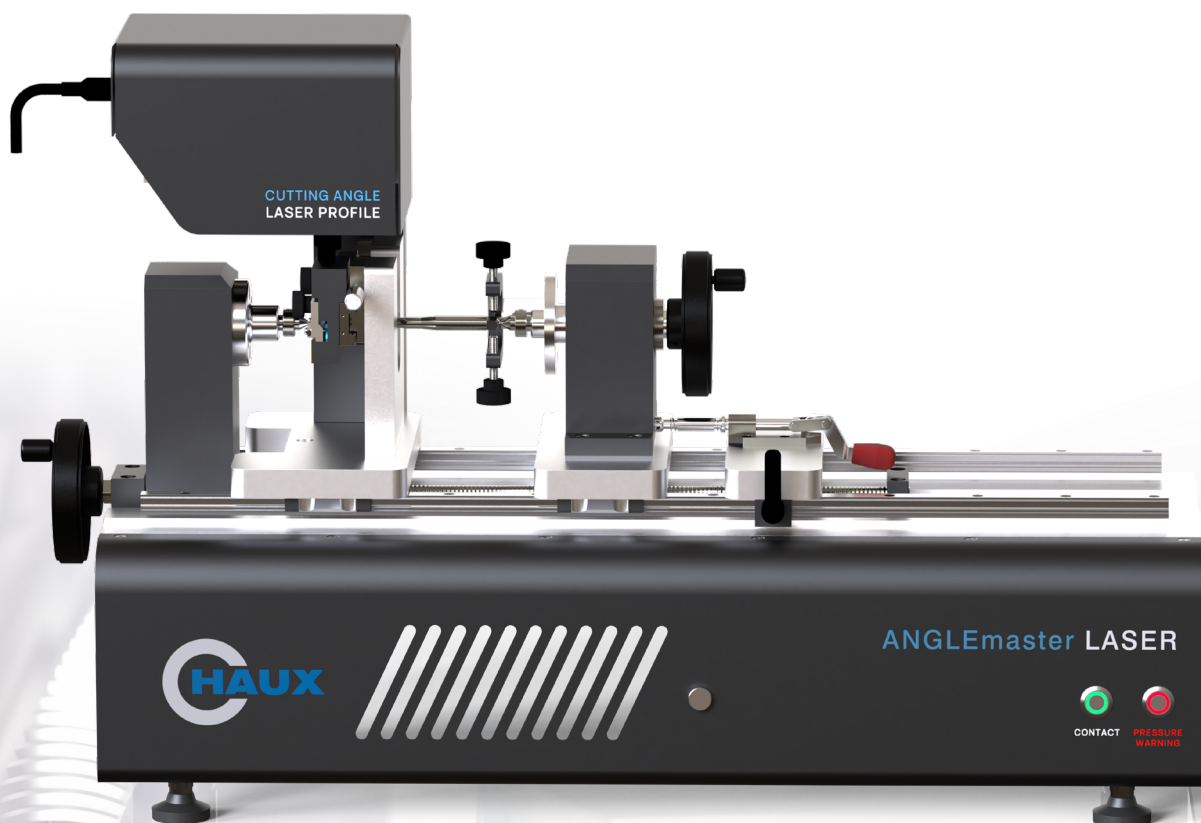



CUTTING ANGLE
LASER PROFILE

ANGLEmaster LASER

High precision cutting angle

The device uses the KEYENCE LJ-X8080 Laser sensor for profile generation to measure the cutting angle of fluted cylindrical cutting tools. The workpiece is clamped between centers and a physical stop is used to align the cutting edge horizontally on the same height as the center workpiece axis.

The device needs to be connected to a PC and Screen. A small PC can be integrated into the housing of the device and can be sold and setup by HAUX if no PC is provided by customer.

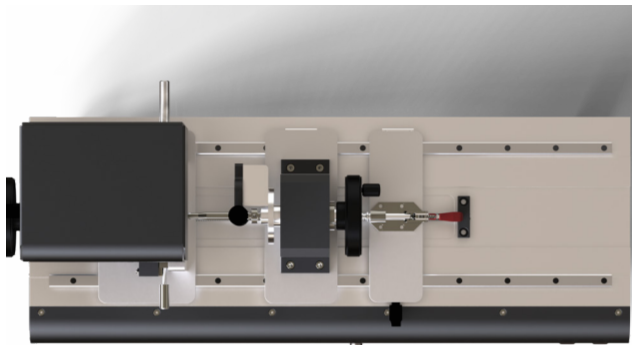

The device is made to be easily expandable to fit your max workpiece length.

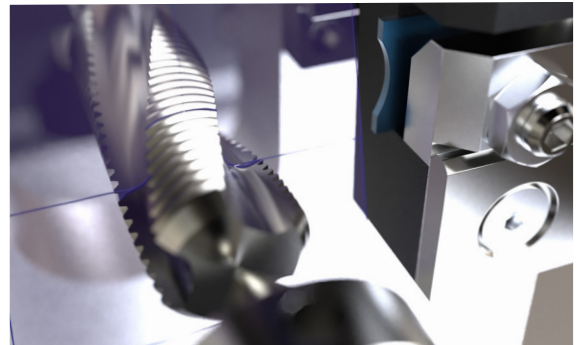

Alignment stop made of cheap rectangular symmetrical plates with a quick change system.

The stop plate can be rotated to use all edges until worn.

An electrical contact sensor allows quick alignment of the cutting edge and reduces human error.



ANGLEmaster LASER

High end laser profile sensor

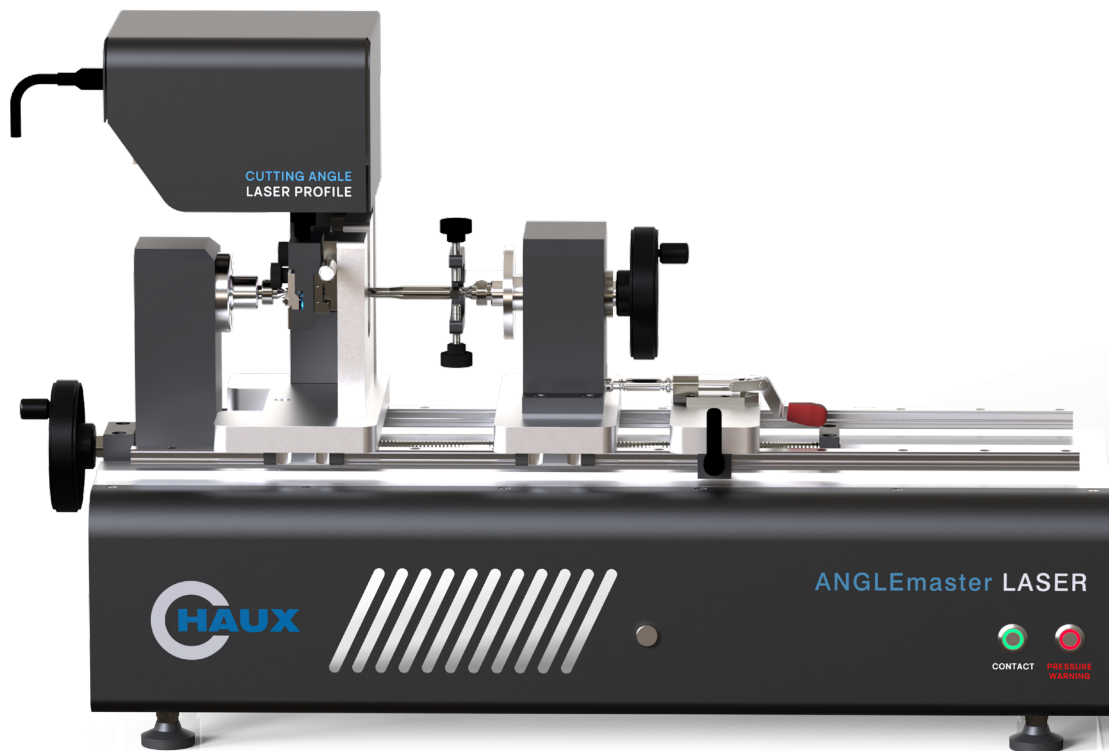

Specifications

Workpiece diameter: 2 - 34 mm

Workpiece length: max 350 mm

Dimensions (L / W / D): ca. 750 x 520 x 283 mm

Main components

- KEYENCE LJ-X8080 Laser Profile Sensor
- Electrical contact sensor for alignment
- Software either by HAUX optimized for quick and easy cutting angle measurements or general Keyence measuring software





Profile generation Keyence LJ-X

The KEYENCE LJ-X8080 generates a precise profile of the workpiece. After a quick alignment of the cutting edge the cutting angle is measured.

Model		LJ-X8080
Reference distance		73 mm
Measurement range	Z-axis (height)	±20.5 mm (F.S.=41 mm)
	X-axis (width)	NEAR side 30 mm Reference distance 35 mm FAR side 39 mm
Light source		Blue semiconductor laser
Light source	Wavelength	405 nm (visible light)
	Laser class	Class 2M laser product (IEC60825-1, FDA (CDRH) Part 1040.10 ¹¹) ²
	Output	10 mW
Spot size		Approx. 44 mm × 72 μm (reference distance)
Repeatability	Z-axis (height)	0.5 μm ^{3,4}
	X-axis (width)	1.0 μm ^{3,5}
Linearity	Z-axis (height)	±0.03% of F.S. (±0.004%) ⁶
Profile data interval	X-axis (width)	12.5 μm (10 μm~) ^{7,8}
Profile data count		3200 points
HDR (high dynamic range)		Single-shot HDR ⁹
Laser irradiation position confirmation function	Light source	Blue LED (405 nm)
Temperature characteristic		0.01% of F.S./°C
Environmental resistance	Enclosure rating	IP67 (IEC60529) ¹⁰
	Ambient light	Incandescent lamp: 10,000 lux or less ¹¹
	Ambient temperature	0 to +45°C ¹²
	Relative humidity	85% RH or less (no condensation)
	Vibration resistance	10 to 57 Hz, double amplitude 1.5 mm; 3 hours each for X, Y, and Z axes
	Shock resistance	15 G / 6 msec
Material		Aluminium
Weight		Approx. 1100 g

Dimensions

+ 24" PC Screen

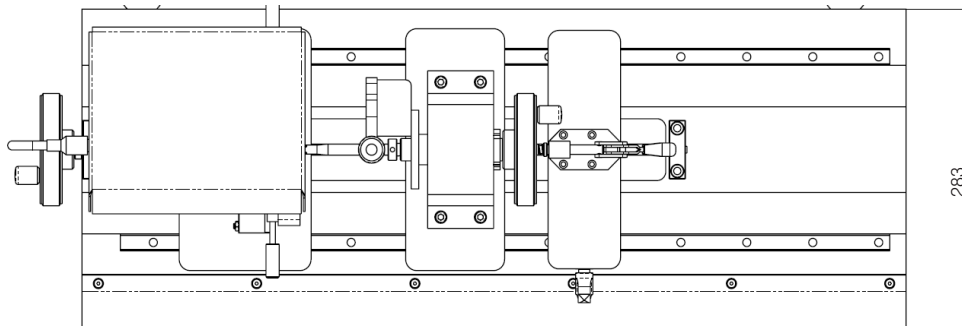
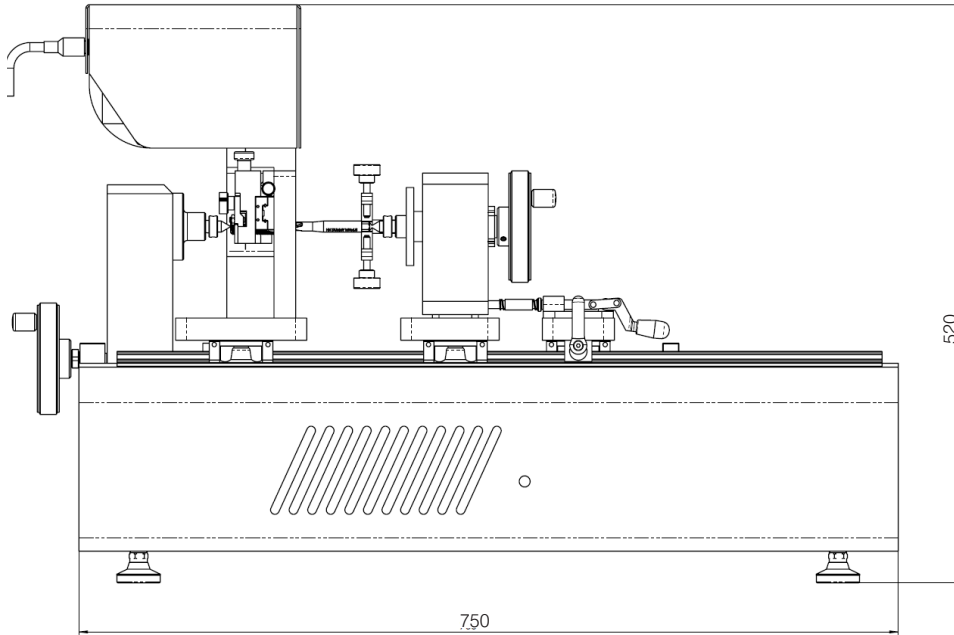

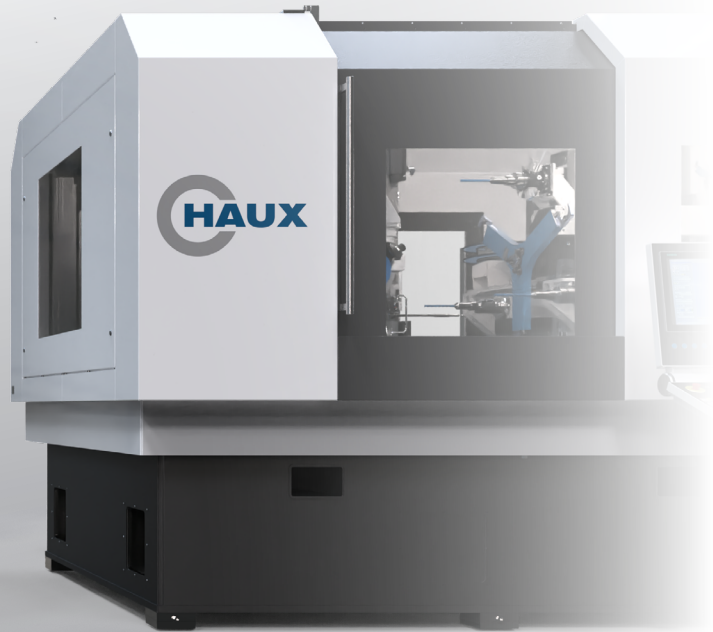

HAUX

MOVING
INNOVATION

For more information visit hauxmt.com or contact us for an individual consultation.

UE Line

Universal Eco - Modular Universal grinding

The UE-Line is our allround talent - flexible and expandable. The 5-Axis grinding kinematic of the base model offers you full flexibility and the extra strong structure of all components allows high speed and feed rates. Many different configurations are possible to specialize for specific production requirements using HAUX Modules.



UP Line

Universal Premium - High End Universal grinding

The HAUX UP-Line offers full autonomy and ultra high precision. Its high precision servo axis lead to a perfect surface finish and the the high end base body eliminates vibrations. The top model the UPT combines two stations with an automation cell inbetween. Collet changes, tool changes and even grinding wheel packet changes can be done fully automatic.



MM Line

High Performance Multi Station

The MM-Line combines two main grinding stations on one base body and offers excellent cycle times using a high end tool changing system that can move the tool between stations and load as well as unload in one single fast movement.



Special

High Performance Multi Station

HAUX has a lot of experience in special applications and individual engineering projects. For special use cases we work closely with our customer to develop the optimal machine for the specific use case.

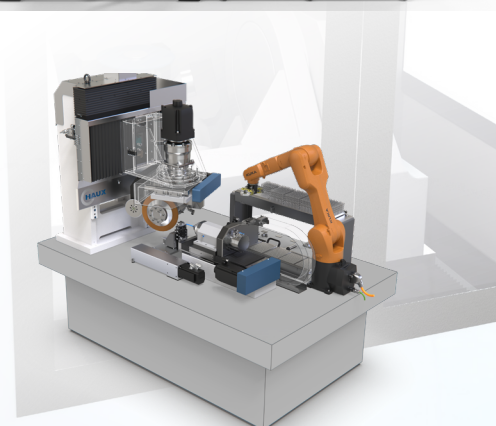



HAUX Machine Tools offers decades of know-how and innovations of the pioneers of high speed grinding.

Contact

HAUX Machine Tools GmbH

Ebinger Str. 50
72510 Stetten a.k.M
Baden-Württemberg

GERMANY

Phone: +49 (0)7573 95455-0
FAX: +49 (0)7573 95455-30

Internet: hauxmt.com
E-mail: info@hauxgmbh.de



For more information visit
HAUXMT.com