

UP-Line Universal Premium

Flexible - Precise - Autonomous





UP-Line

HAUX Universal Premium

A wide range of modular configurations allows us to provide you with a highly flexible machine that at the same time is set up to do best what you produce the most.



HAUX Universal grinding machines offer outstanding performance and speed with high flexibility.



UP-Line

High Precision Universal grinding machines. Autonomous production optional.



Universal Premium

Universal high precision tool grinding

Specifications

(*varies depending on configuration and can be extended for special use case)

Workpiece length (auto.): max. 320 mm

Workpiece diameter (auto.): 3.00 mm - 12.7 mm

Grinding wheel diameter: max. 200 mm

Spindle power: 22 kW

Speed: 12.000 rpm

Dimensions: 4.00 x 3.00 x 2.50 m

Kinematic

5 Axis + Workpiece support

(* second workpiece support axis possible)

	Travel	Resolution
X - Axis:	713 mm	< 0.001 mm
Y - Axis:	289 mm	< 0.001 mm
Z - Axis:	289 mm	< 0.00 mm
C - Axis:	-122° to 122°	< 0.005°
A - Axis:	360°	< 0.005°

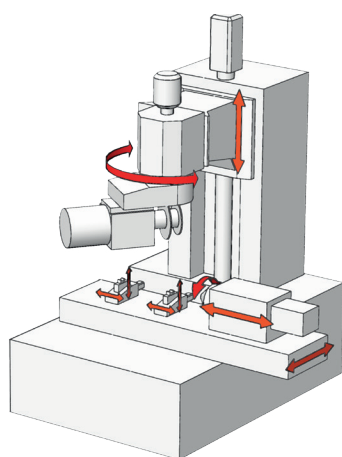

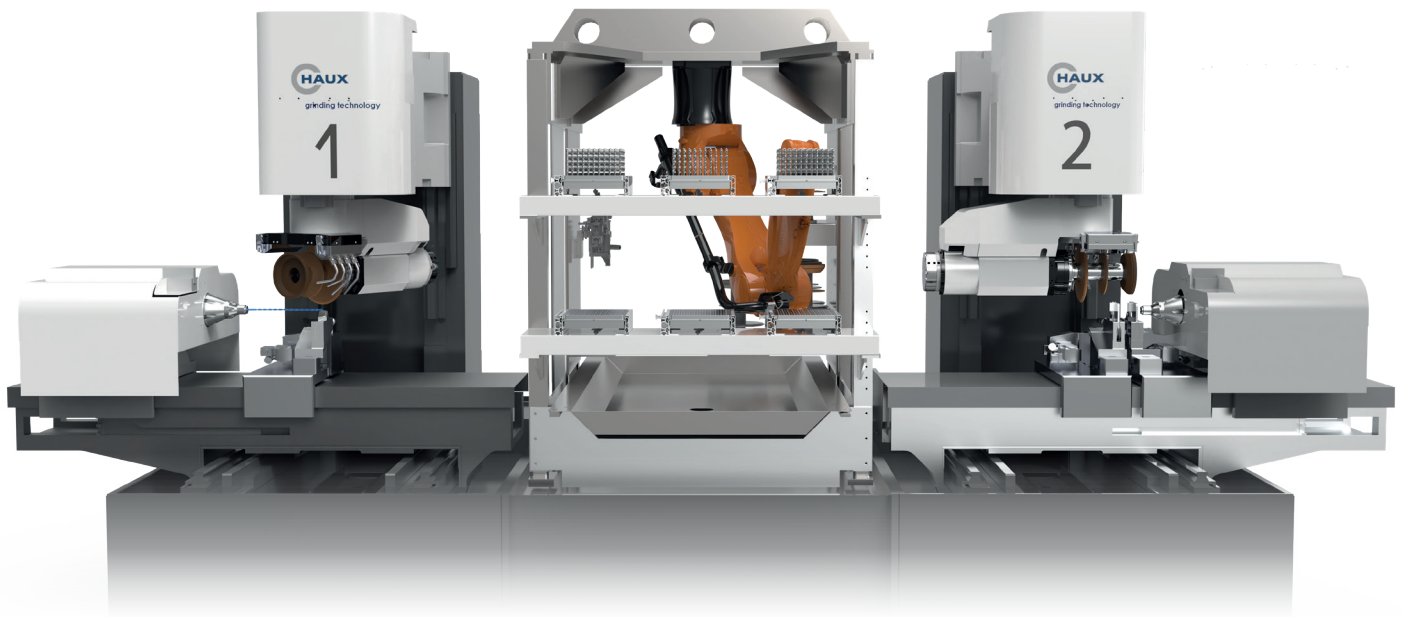

Machine Configurations

Your configuration for your application

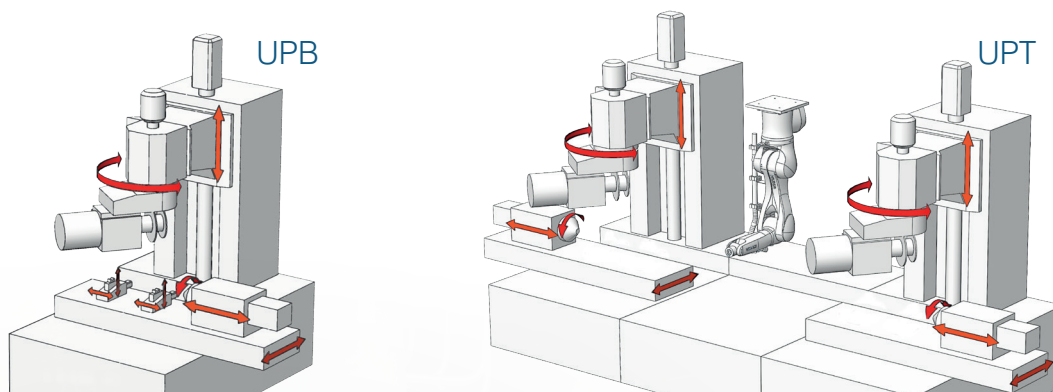

The UP-Line combines high end components in a powerful universal grinding machine that can be highly automated. With two grinding stations sharing one automation cell inside a combined machine the UPT is the top model of the line.



Modules

The UP-Line uses high precision components to meet highest standards

Workpiece carrier

Hydrostatic precision

The hydrostatic workpiece carrier with 1100 rpm and 1.1 kW uses a high precision clamping system that allows automated collet changes.

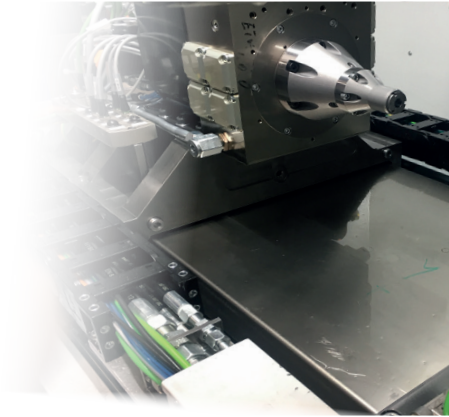

Arobotec

High precision workpiece support

Perfect centric clamping system by Arobotec allows high precision and accuracy and offers fast and flexible setup.

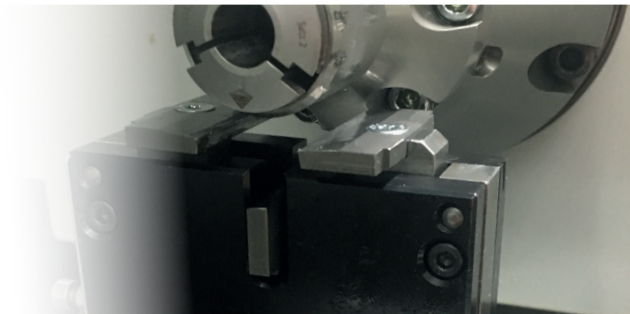

Grinding spindle

High speed - High precision

The high end german made motor spindle allows automatic grinding wheel changes and high precision grinding.

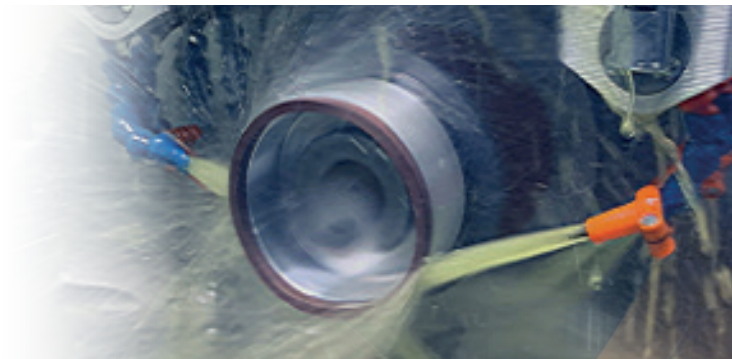

Layout

Parallel operation of both grinding stations leads to superior cycle times and high production output.

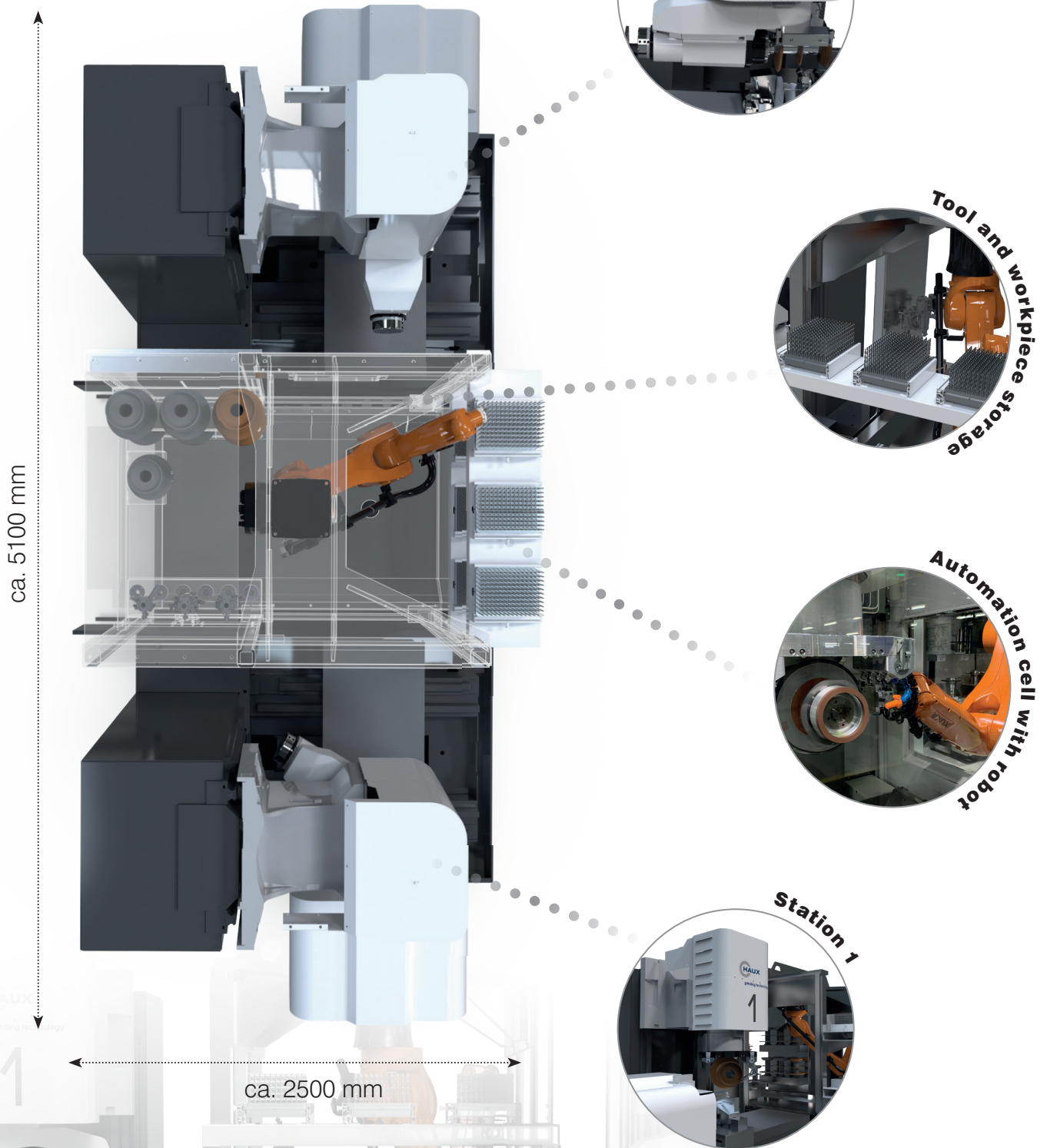

HAUX

Software

Modular - Expandable - Integrated

Our modular software runs on single machines as well as multi station machines or machines integrated in manufacturing cells. It allows integration into your company's network. Part, order, tooling or measurement data is easily exchanged. Autonomous operation of our machines is optional.

HAUX uses its own software on NC- and PLC-level and cooperates with MTS Switzerland for special use cases. HAUX own profiling software offers great value and specialized optimization for intended applications.

Remote access is offered by default and a new RED-box offers secure high volume data exchange and machine monitoring.

Applications

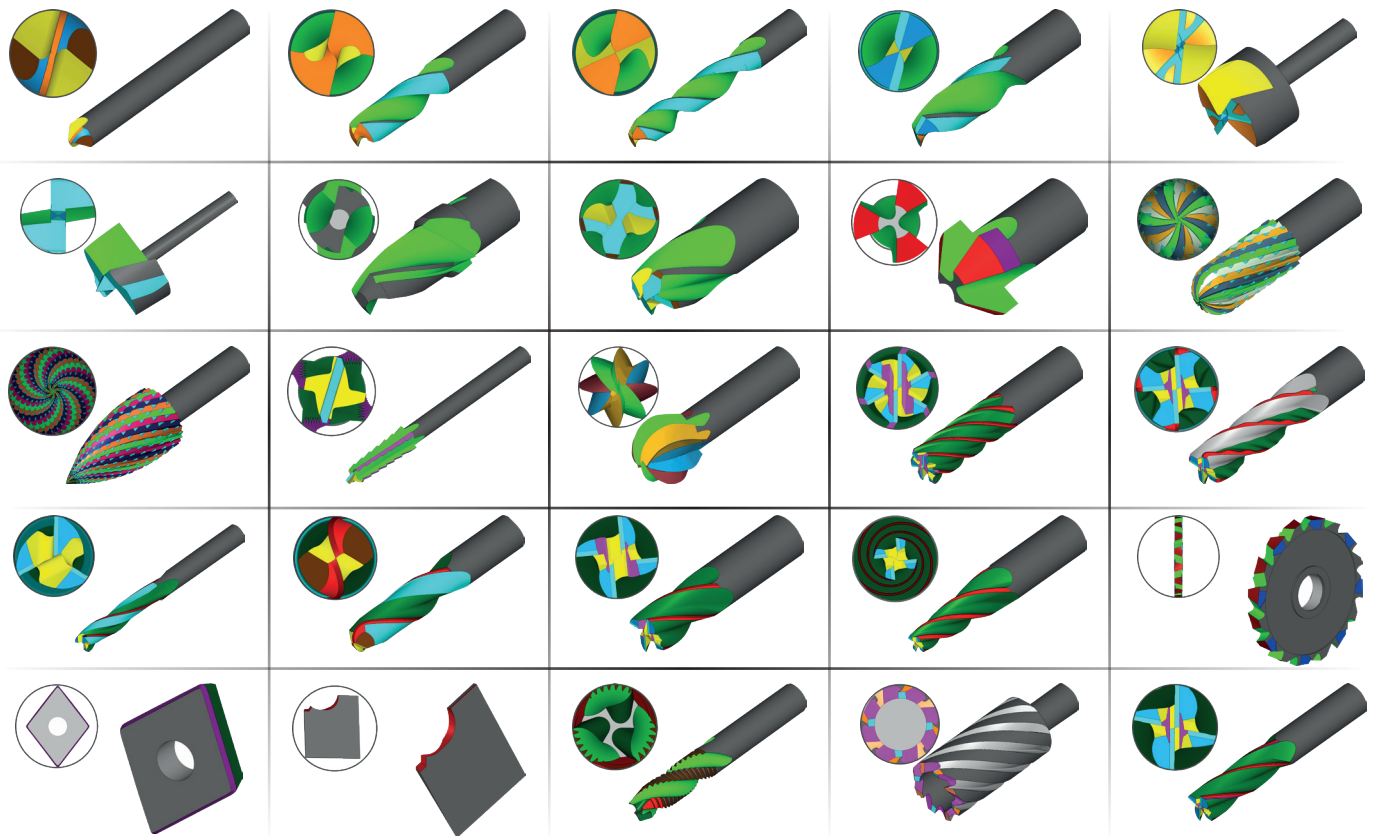

HAUX HMI

Individual UI - Preview / Simulation



HAUX HMI with parametric tool definition includes live preview of each parameter's effect and on screen explanations.

Current process values are displayed during operation.



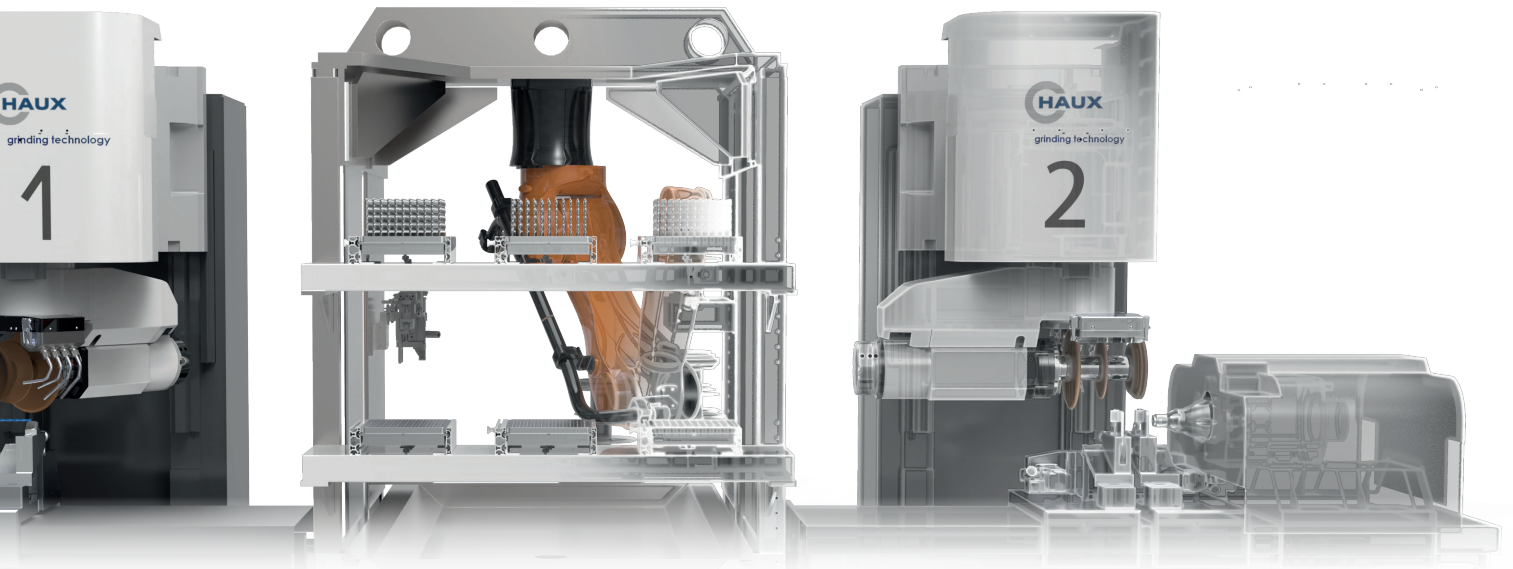

HAUX Machine Tools Automation

Elevate performance to the next level

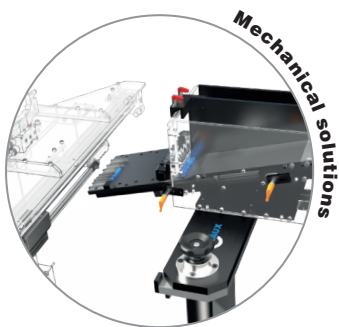

Mechanical solutions

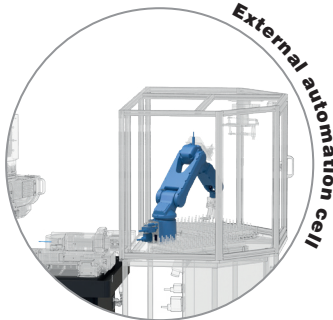

External automation cell



Integrated automation cell

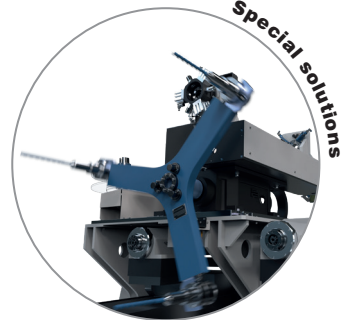

Special solutions



Robot out

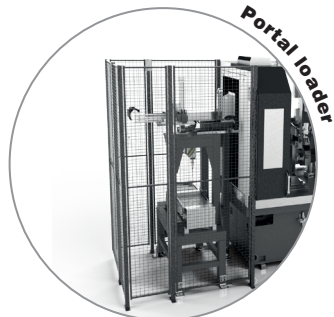

Portal loader



Portal connecting machines

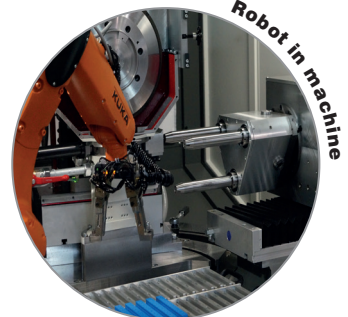

Robot in machine



HAUX offers the best automation solution for every situation.

Automation Options

Examples of automation solutions used in HAUX machines

Mechanical Solutions

High quality engineering

HAUX Machine Tools offers decades of know-how and innovations of the pioneers of high speed grinding. High speed workpiece loading and unloading using magazines and indexing mechanisms offers top speeds in many use cases.

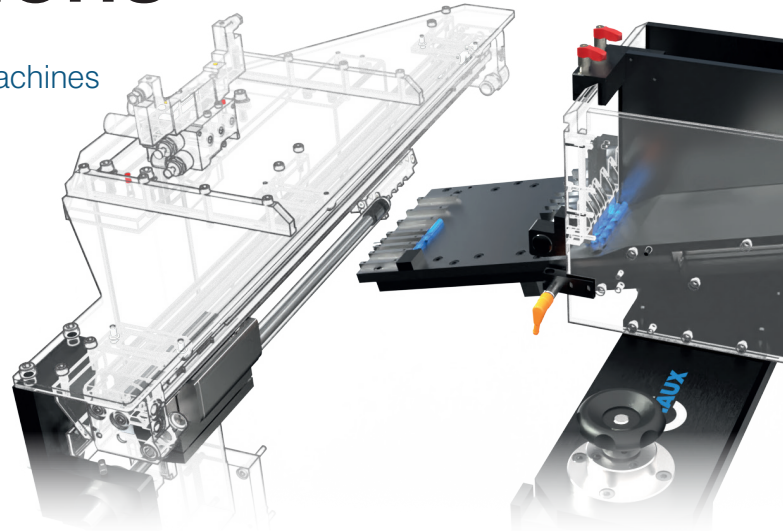

Robotics

Flexible and universal

Industrial robots offer a great balance of cost and flexibility and can even be used to automate grinding wheel changes. Lots of custom grippers, storage, indexing- and orienting solutions let us customize the scope of the robotic automation of your machine when needed.

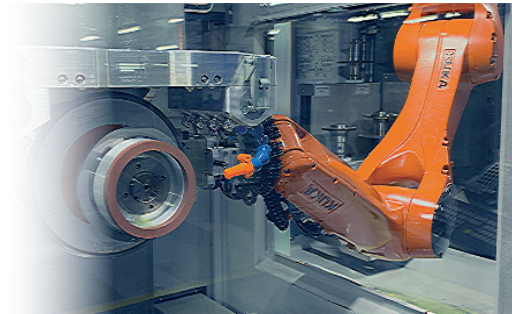

Portal & Production Line Integration

For seamless production

Portals can offer better speeds versus robots for applicable use cases and still remain a lot of the same flexibility.

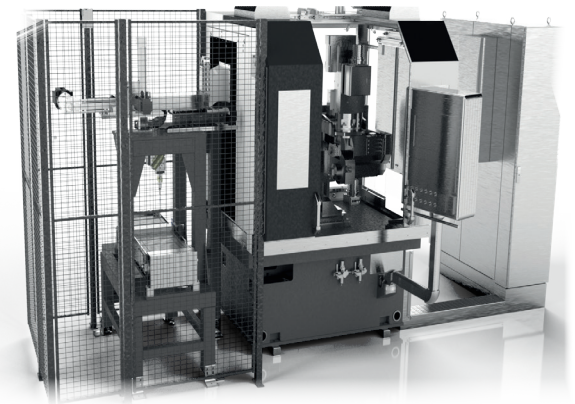

Special Solutions

For high speed and special customer needs

HAUX has a lot of experience in special applications and individual engineering projects. For special use cases we work closely with our customer to develop the optimal machine for the specific use case.

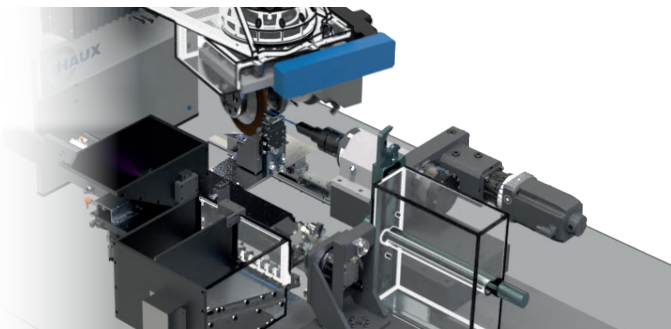

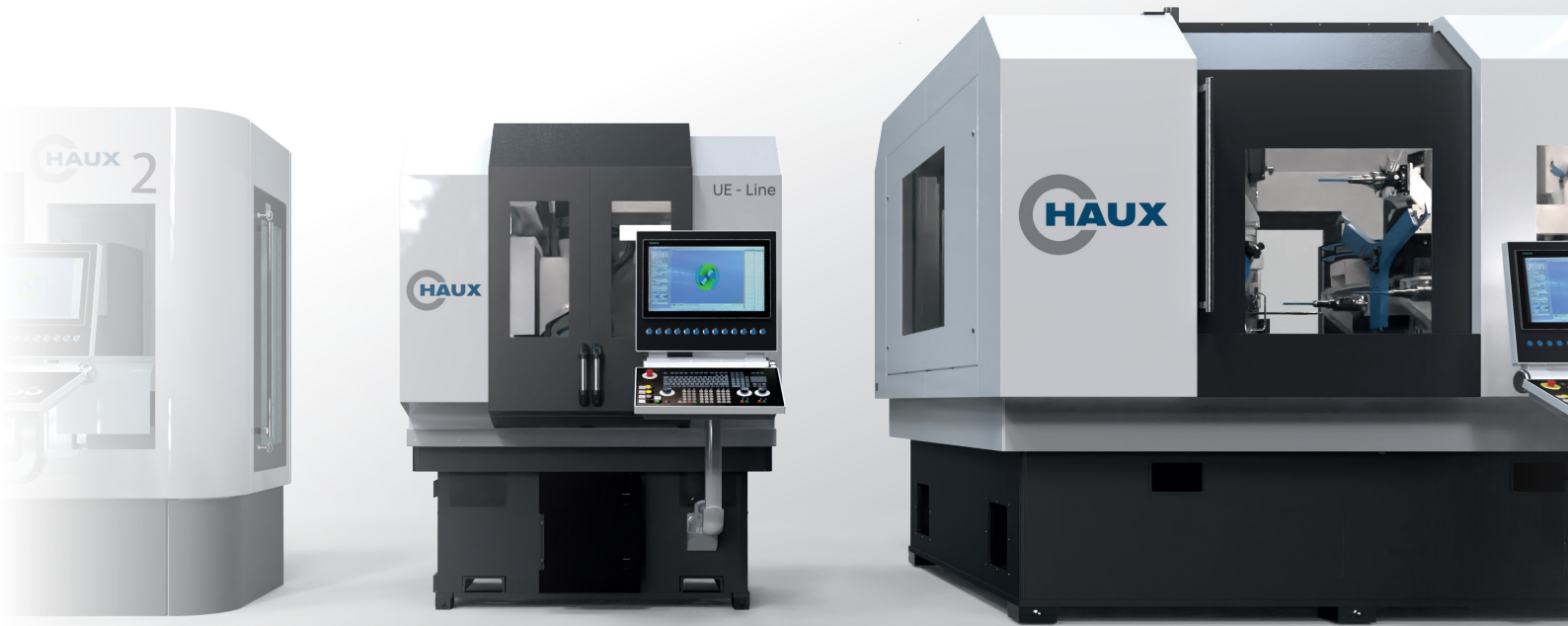

HAUX

MOVING
INNOVATION

For more information visit hauxmt.com or contact us for an individual consultation.

UE Line

Universal Eco - Modular Universal grinding

The UE-Line is our allround talent - flexible and expandable. The 5-Axis grinding kinematic of the base model offers you full flexibility and the extra strong structure of all components allows high speed and feed rates. Many different configurations are possible to specialize for specific production requirements using HAUX Modules.



UP Line

Universal Premium - High End Universal grinding

The HAUX UP-Line offers full autonomy and ultra high precision. Its high precision servo axis lead to a perfect surface finish and the the high end base body eliminates vibrations. The top model the UPT combines two stations with an automation cell inbetween. Collet changes, tool changes and even grinding wheel packet changes can be done fully automatic.



MM Line

High Performance Multi Station

The MM-Line combines two main grinding stations on one base body and offers excellent cycle times using a high end tool changing system that can move the tool between stations and load as well as unload in one single fast movement.



Special

High Performance Multi Station

HAUX has a lot of experience in special applications and individual engineering projects. For special use cases we work closely with our customer to develop the optimal machine for the specific use case.

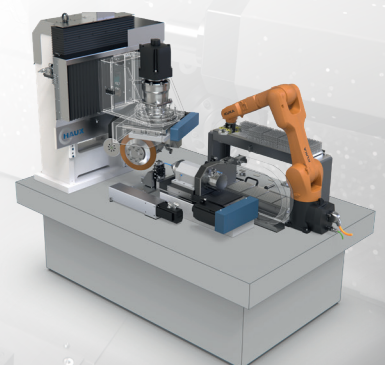

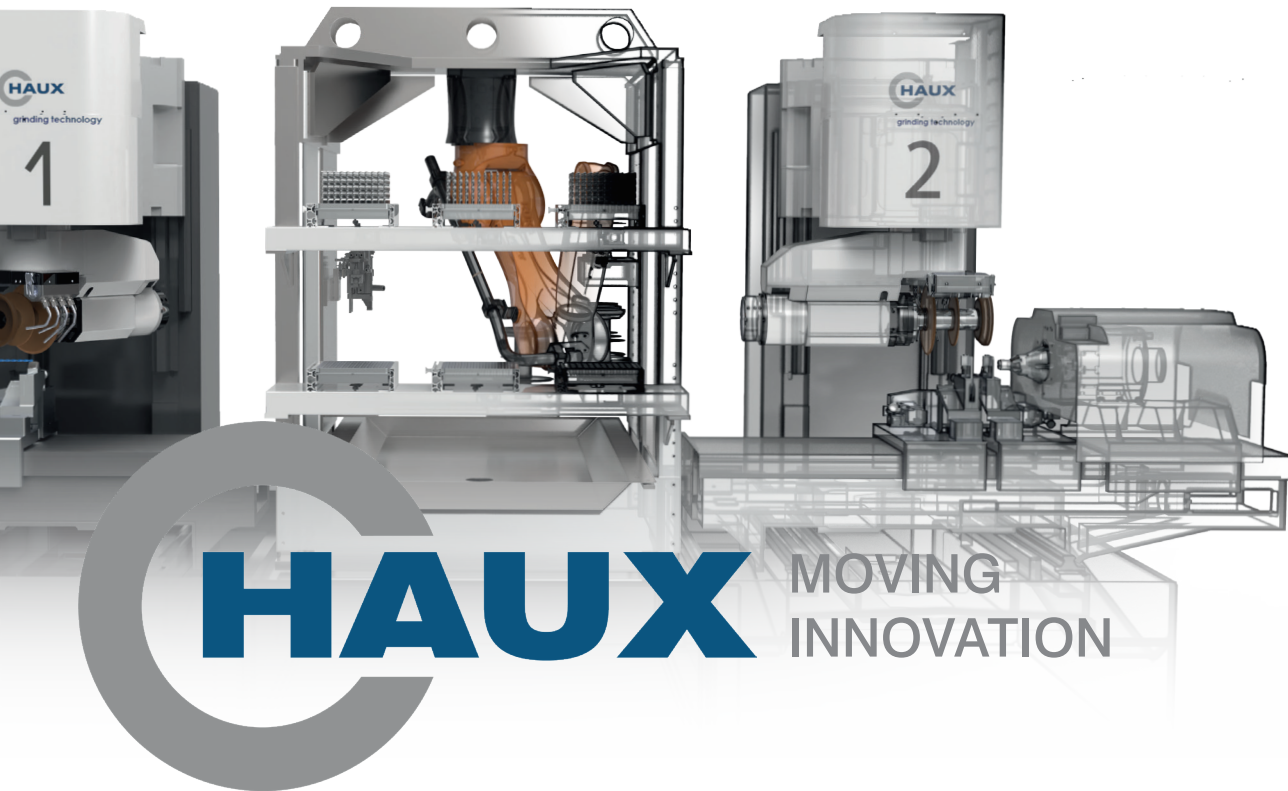

HAUX Machine Tools offers decades of know-how and innovations of the pioneers of high speed grinding.

Contact

HAUX Machine Tools GmbH

Ebinger Str. 50
72510 Stetten a.k.M
Baden-Württemberg

GERMANY

Phone: +49 7573 95455-0
FAX: +49 7573 95455-30

Internet: hauxmt.com
E-mail: info@hauxgmbh.de

International

HAUX JAPAN Office
Phone: +49 6930 0646 20
E-Mail: m.westermann@hauxgmbh.de
Contact: Mr. Westermann

HAUX INDIA Office
411041 Pune
INDIA
Phone: +91 83081 06677
E-Mail: m.deshpande@hauxgmbh.de
Contact: Mr. Deshpande

HAUX RUSSIA / BELARUS /
KAZAKHSTAN Office
ATE Tools GmbH
Phone: +49 7433 908949 20
E-Mail: a.teichert@hauxgmbh.de
Contact: Mr. Teichert

HAUX FRANCE Office
Phone: +49 7435 8251
E-Mail: m.maisch@hauxgmbh.de
Contact: Mrs. Maisch



For more Information visit
HAUXMT.com