

UE-Line Universal Eco

Flexible - Fast - Modular



HAUX



UE-Line HAUX Universal

A wide range of modular configurations allows us to provide you with a highly flexible machine that at the same time is set up to do best what you produce the most.



HAUX Universal grinding machines offer outstanding performance and speed with high flexibility.

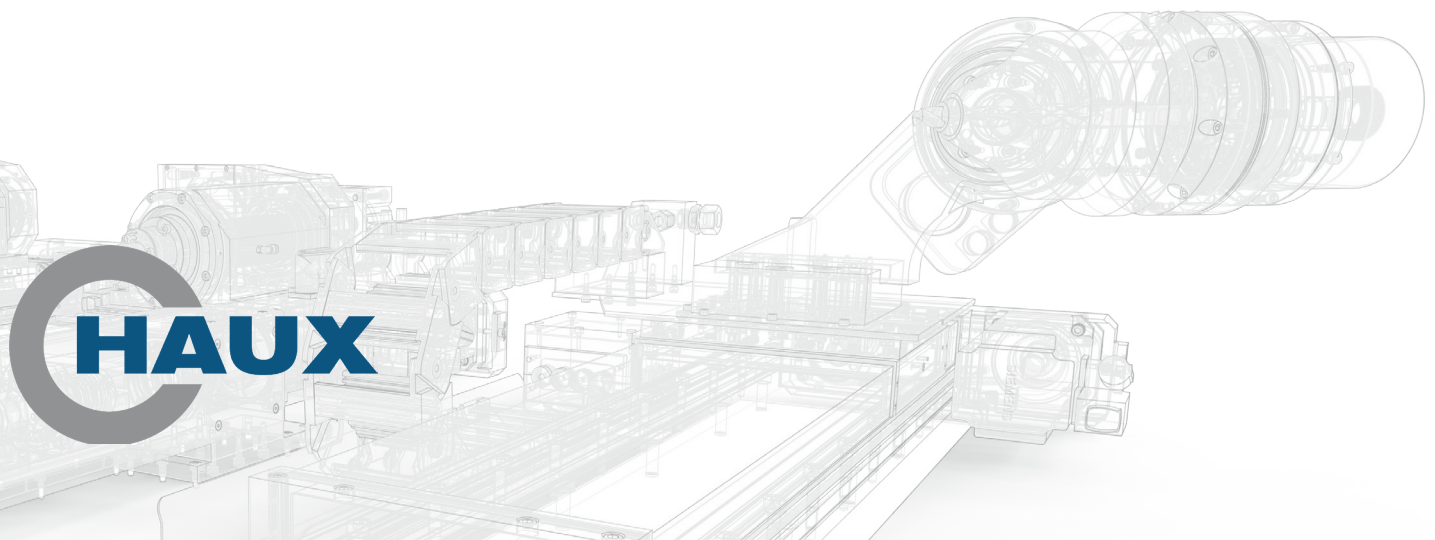

UE-Line

As the base model of the Universal Line the UE is already an excellent allround talent. The 5-Axis grinding kinematic offers you full flexibility and the extra strong structure of all components allows high speed and feed rates.

Universal Eco

Universal tool grinding

Specifications

(*varies depending on configuration and can be extended for special use case)

Workpiece length (auto.): 34 mm - 220 mm

Workpiece length (man.): 300 mm

Workpiece diameter (auto.): 3 mm - 52 mm

Workpiece diameter (man.): 52 mm - 130 mm

Grinding wheel diameter: 200 mm

Dressing wheel diameter: 150 mm
(no dresser in CBN-Model)

Spindle power S1: 15.7 kW

Spindle power S6 40%: 20.0 kW

Kinematic

5 Axis (UEB)

(*stationary dresser in base model; no dresser in CBN-Model)

| | Travel | Resolution |
|-----------|-------------|------------|
| X - Axis: | 250 mm | < 0.002 mm |
| Y - Axis: | 309 mm | < 0.002 mm |
| Z - Axis: | 215 mm | < 0.002 mm |
| C - Axis: | -91° to 65° | < 0.005° |
| A - Axis: | 360° | < 0.005° |

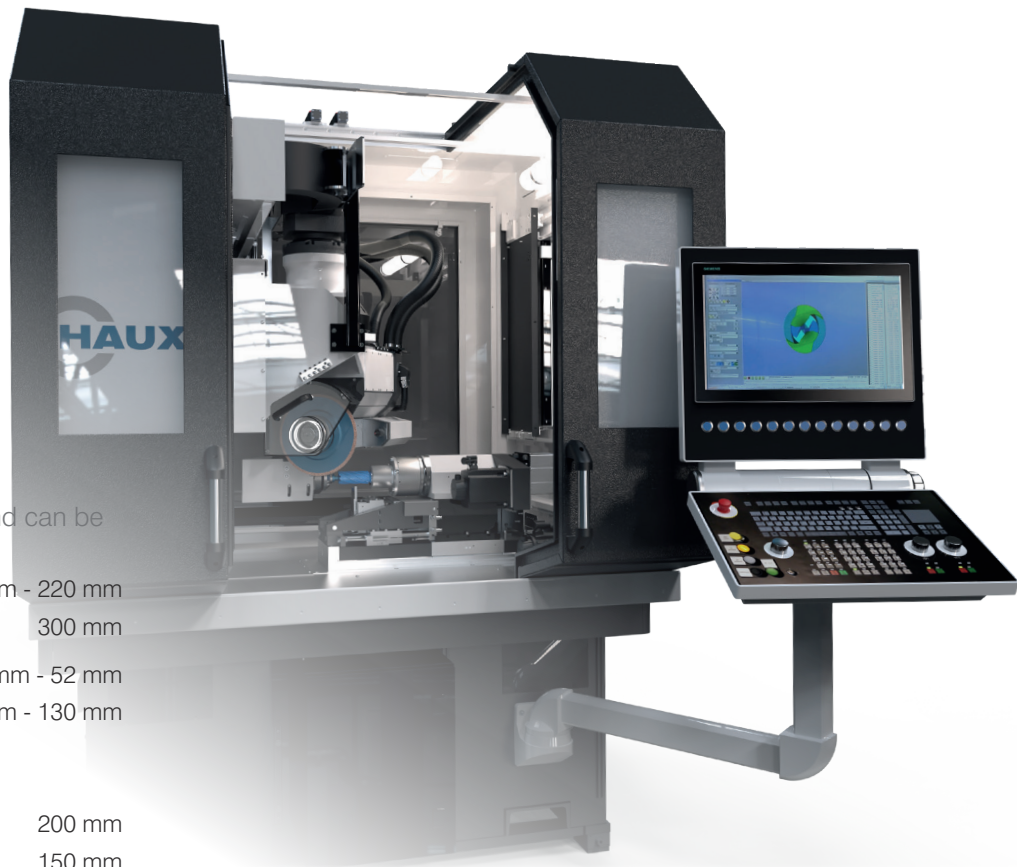
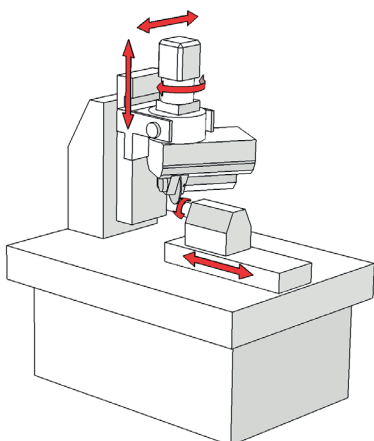

Modular expansion

Customization using existing solutions

Depending on your application various modules can be used to specialize or upgrade your machine configuration.

Workpiece carrier and support systems specialized in



point-/split point grinding, chamfer grinding or universal grinding are available.

Aside from electronic probing systems HAUX offers a wide range of mechanical indexing solutions for different applications.



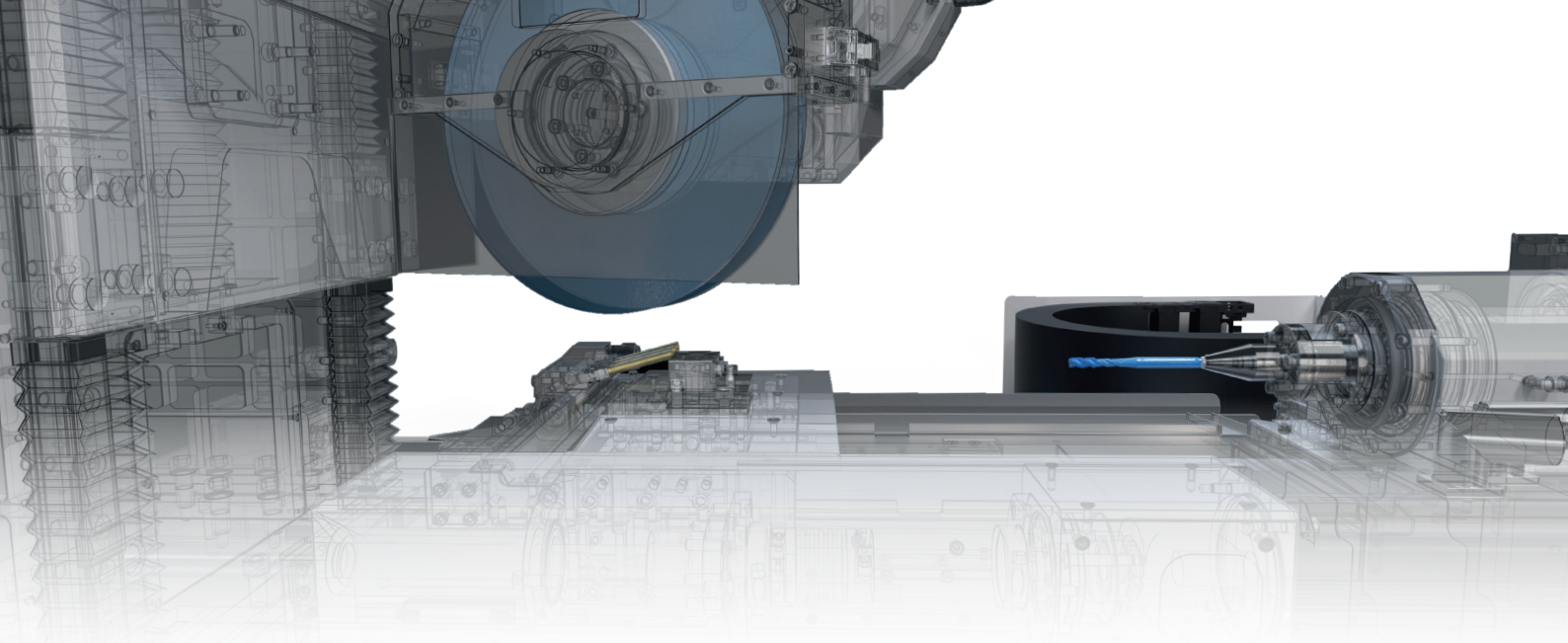

Machine Configurations

Your configuration for your application

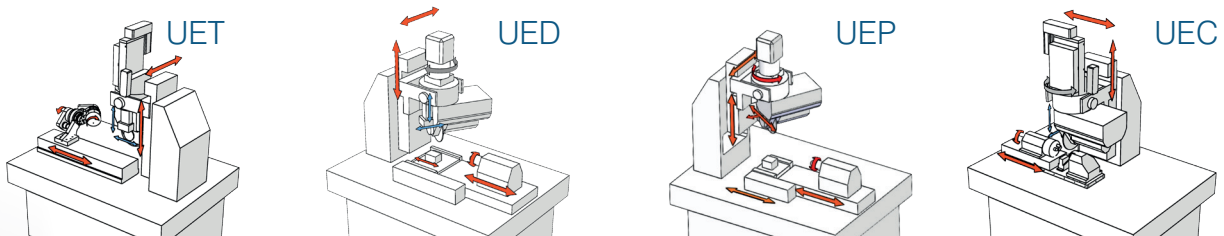

The UE-Line includes preconfigured machines that specialize in chamfer grinding of taps (UEC), Point grinding for spiral taps (UET) or fast universal point grinding (UEP). These machines offer proven modular combinations that lead to excellent results in their specialization.

HAUX Modules expand the scope of our machines and give you the choice in what kind of machine you will get.

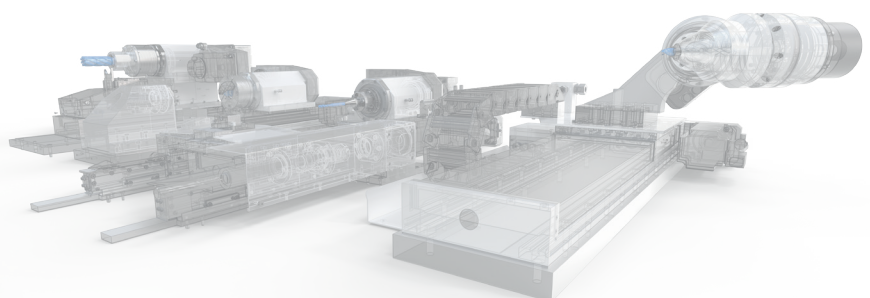

Modules

Decades of development and special engineering projects have created a huge portfolio of various standardized as well as specialized variations of every assembly built in a tool grinding machine.

Workpiece support - UED

Universal tool grinding

Many different workpiece support systems from universal to highly specialized are available for the UE-Line.

For more flexibility the workpiece support in the UE-Line can be upgraded to the CNC version.

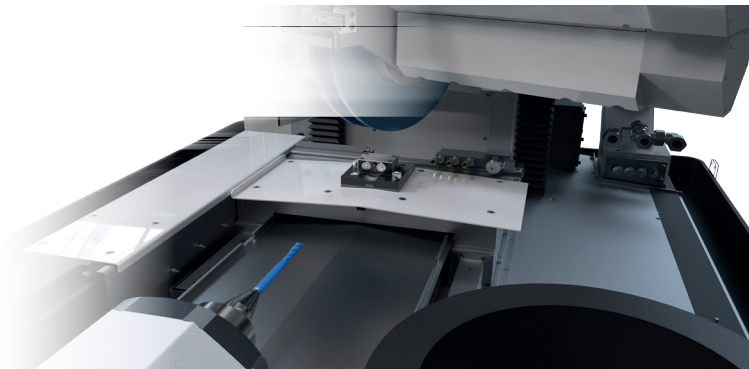
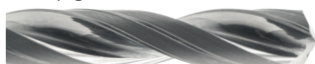

ID grinding - UEI

Customization using existing solutions

The HAUX ID-Grinding Module lets you expand what your machine can do and save cost.

The precise motor spindle can be mounted to the main spindle without need for additional CNC axis.

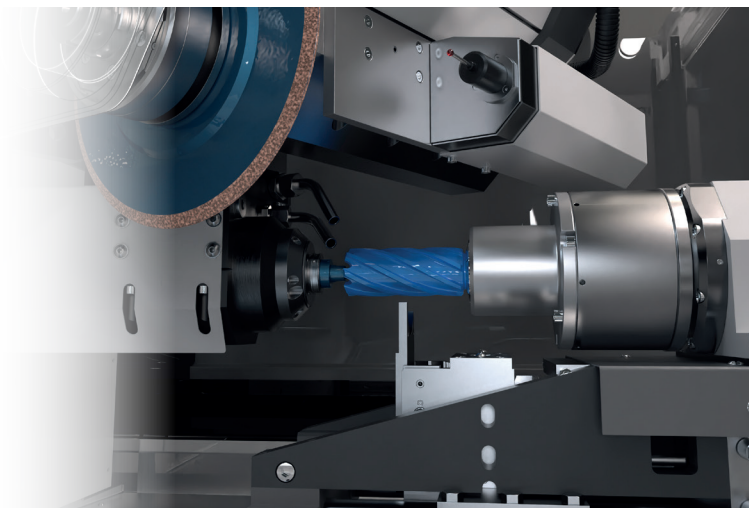

Centers - UEC

For precise OD-Grinding

The centers available for the UE-Line are best suited for fast chamfer grinding of taps or other OD-Grinding operations.



HAUX Universal grinding machines offer outstanding performance.

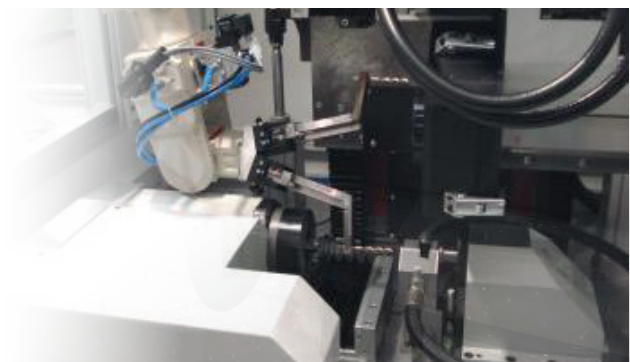

More Modules

The right Module for every application

Dresser & Workpiece support

For high quality surface finishes

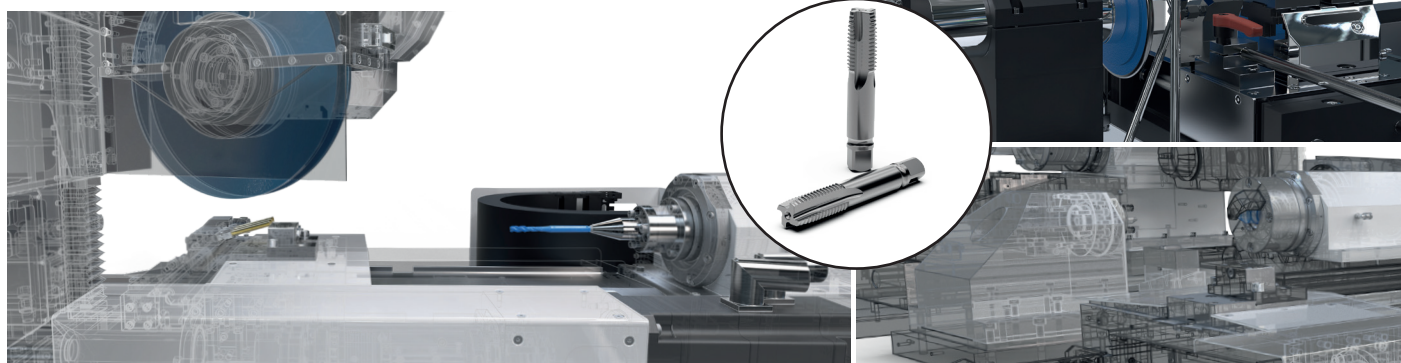

Probes

High precision

Precision probes by Renishaw can be equipped.

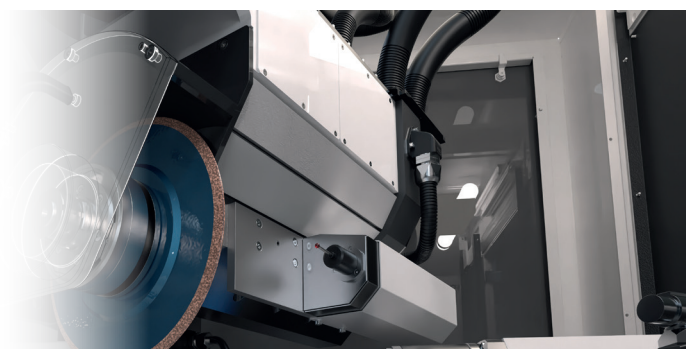

3 - 20 mm

Wide diameter range without collet change

A GDS Shark clamping system can be equipped to allow variable clamping without having to switch collets.



Software

Modular - Expandable - Integrated

Our modular software runs on single machines as well as multi station machines or machines integrated in manufacturing cells. It allows integration into your company's network. Part, order, tooling or measurement data is easily exchanged. Autonomous operation of our machines is optional.

HAUX uses its own software on NC- and PLC-level and cooperates with MTS Switzerland for special use cases. HAUX own profiling software offers great value and specialized optimization for intended applications.

Remote access is offered by default and a new RED-box offers secure high volume data exchange and machine monitoring.

Applications

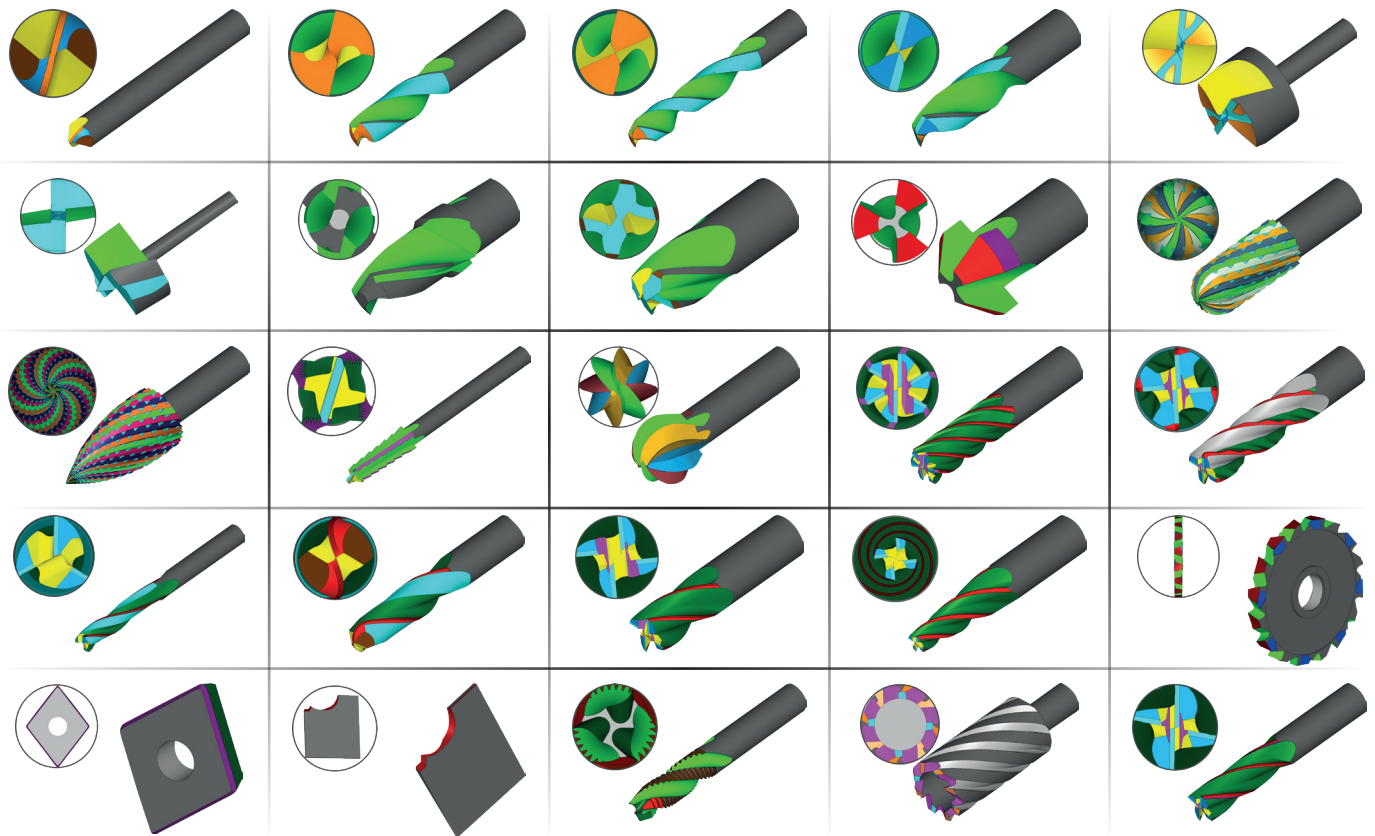

HAUX HMI

Individual UI - Preview / Simulation



HAUX HMI with parametric tool definition includes live preview of each parameter's effect and on screen explanations.

Current process values are displayed during operation.



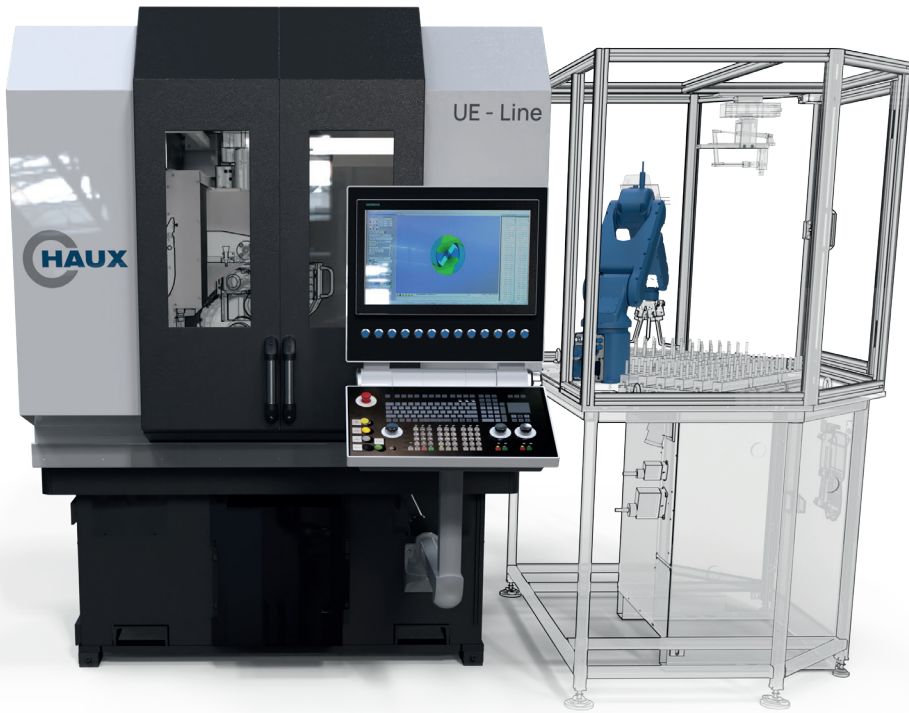

HAUX

Automation

Elevate performance to the next level

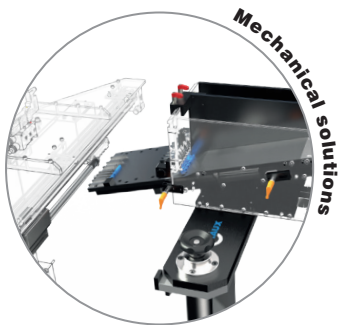

Mechanical solutions

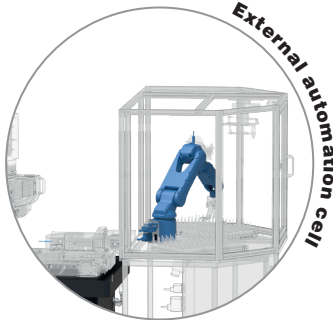

External automation cell



Integrated automation cell



Special solutions



Robot outd

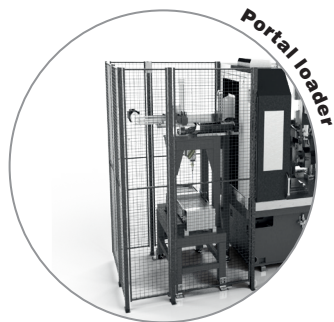

Portal loader



Portal connecting machines

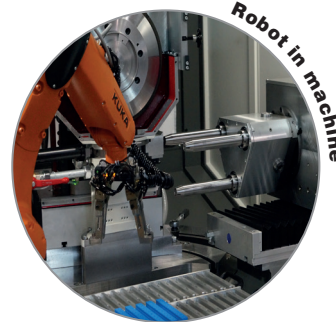

Robot in machine



HAUX offers the right automation solution for every situation with decades of know-how and experience in automation, engineering and tool grinding,

Automation Options

Examples of automation solutions used in HAUX machines

Mechanical Solutions

High quality engineering

HAUX Machine Tools offers decades of know-how and innovations of the pioneers of high speed grinding. High speed workpiece loading and unloading using magazines and indexing mechanisms offers top speeds in many use cases.

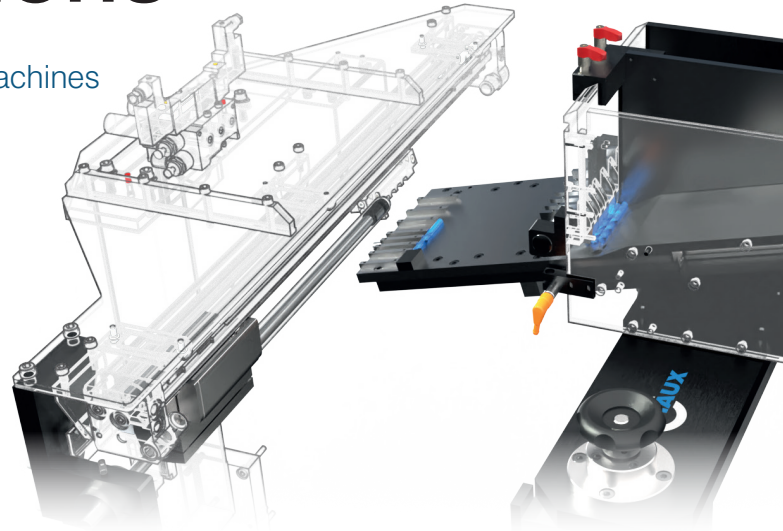

Robotics

Flexible and universal

Industrial robots offer a great balance of cost and flexibility and can even be used to automate grinding wheel changes. Lots of custom grippers, storage, indexing- and orienting solutions let us customize the scope of the robotic automation of your machine when needed.

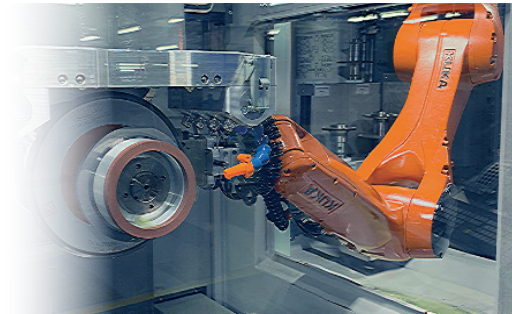

Portal & Production Line Integration

For seamless production

Portals can offer better speeds versus robots for applicable use cases and still remain a lot of the same flexibility.

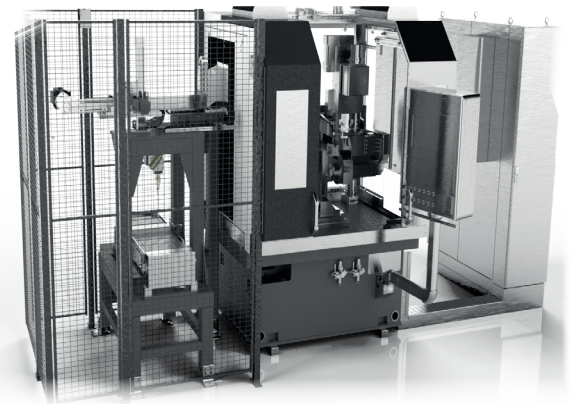

Special Solutions

For high speed and special customer needs

HAUX has a lot of experience in special applications and individual engineering projects. For special use cases we work closely with our customer to develop the optimal machine for the specific use case.

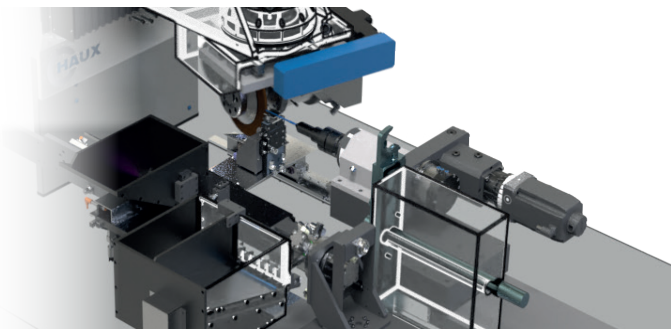

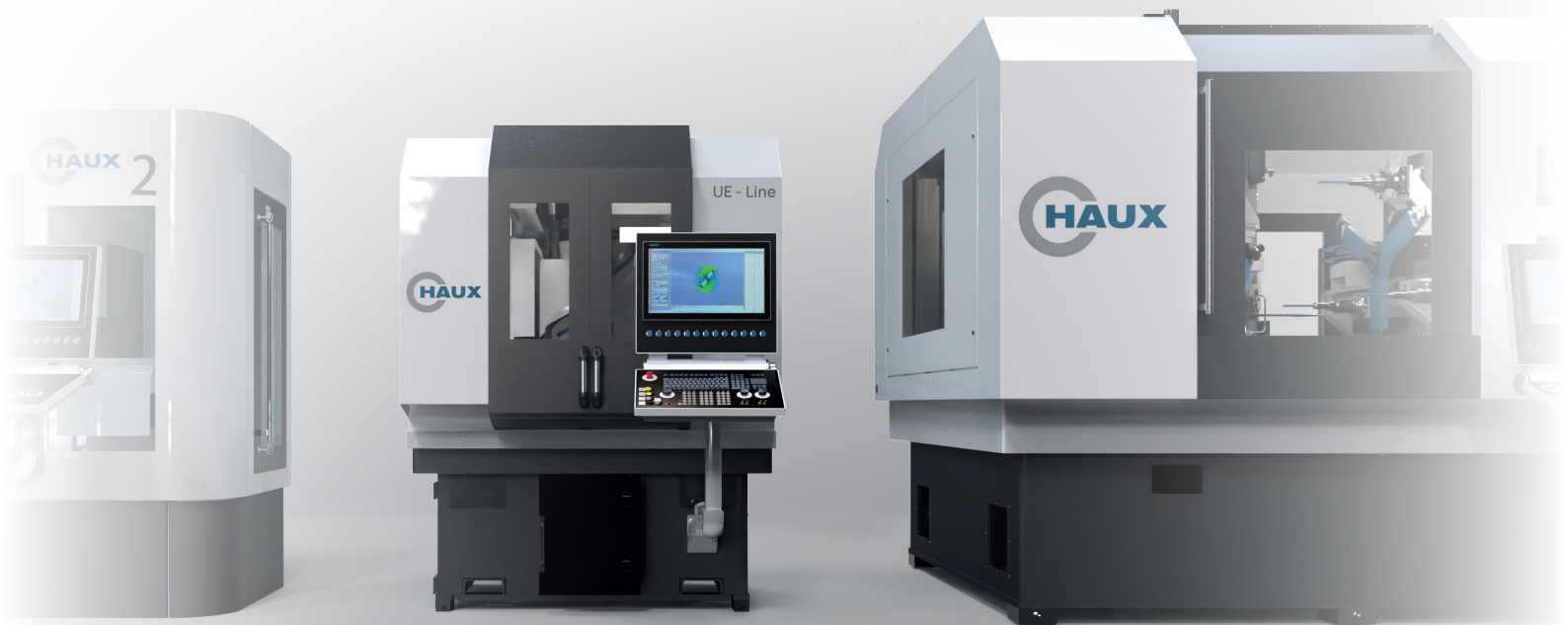

HAUX MOVING INNOVATION

For more information visit hauxmt.com or contact us for an individual consultation.

UE Line

Universal Eco - Modular Universal grinding

The UE-Line is our allround talent - flexible and expandable. The 5-Axis grinding kinematic of the base model offers you full flexibility and the extra strong structure of all components allows high speed and feed rates. Many different configurations are possible to specialize for specific production requirements using HAUX Modules.



UP Line

Universal Premium - High End Universal grinding

The HAUX UP-Line offers full autonomy and ultra high precision. Its high precision servo axis lead to a perfect surface finish and the the high end base body eliminates vibrations. The top model the UPT combines two stations with an automation cell inbetween. Collet changes, tool changes and even grinding wheel packet changes can be done fully automatic.



MM Line

High Performance Multi Station

The MM-Line combines two main grinding stations on one base body and offers excellent cycle times using a high end tool changing system that can move the tool between stations and load as well as unload in one single fast movement.



Special

High Performance Multi Station

HAUX has a lot of experience in special applications and individual engineering projects. For special use cases we work closely with our customer to develop the optimal machine for the specific use case.

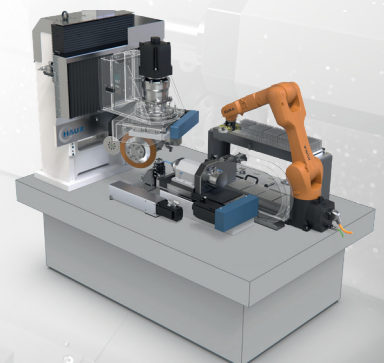



HAUX Machine Tools offers decades of know-how and innovations of the pioneers of high speed grinding.

Contact

HAUX Machine Tools GmbH

Ebinger Str. 50
72510 Stetten a.k.M
Baden-Württemberg

GERMANY

Phone: +49 7573 95455-0
FAX: +49 7573 95455-30

Internet: hauxmt.com
E-mail: info@hauxgmbh.de

International

HAUX JAPAN Office
Phone: +49 6930 0646 20
E-Mail: m.westermann@hauxgmbh.de
Contact: Mr. Westermann

HAUX INDIA Office
411041 Pune
INDIA
Phone: +91 83081 06677
E-Mail: m.deshpande@hauxgmbh.de
Contact: Mr. Deshpande

HAUX RUSSIA / BELARUS /
KAZAKHSTAN Office
ATE Tools GmbH
Phone: +49 7433 908949 20
E-Mail: a.teichert@hauxgmbh.de
Contact: Mr. Teichert

HAUX FRANCE Office
Phone: +49 7435 8251
E-Mail: m.maisch@hauxgmbh.de
Contact: Mrs. Maisch



For more Information visit
HAUXMT.com