

MM-Line Modular Multi

Universal - Multi Station - Parallel Operation - High Volume





MM-Line

HAUX Universal

Production on two grinding stations for flute, OD and face grinding working simultaneously with a high end automated tool changing system.



HAUX Universal grinding machines offer outstanding performance and speed with high flexibility.



Modular Multi

The MM-Line combines two main grinding stations on one base body and offers excellent cycle times using a high end tool changing system that can move the tool between stations and load as well as unload in one single fast movement.

Features

Universal tool grinding

The modular multi is the latest development in the HAUX line up. Optimized for ultra fast feed rates and low cycle times.

Technical Data

(*varies depending on configuration and can be extended for special use case)

Workpiece length: max. 205 mm
Workpiece diameter: 3 mm - 12 mm

Station 1:

Optimized for flute and OD-grinding

Grinding wheel diameter: 150 mm - 300 mm
Dressing wheel diameter: 150 mm
Flange: HSK-A63

Station 2:

Optimized for point and face grinding

Grinding wheel diameter: 150 mm - 200 mm
Dressing wheel diameter: 150 mm
Flange: HSK-C50

Kinematic

Station 1 7 Axis
(incl. 2 for Dresser)

Station 2 5 Axis

Fast Loader 1 Axis

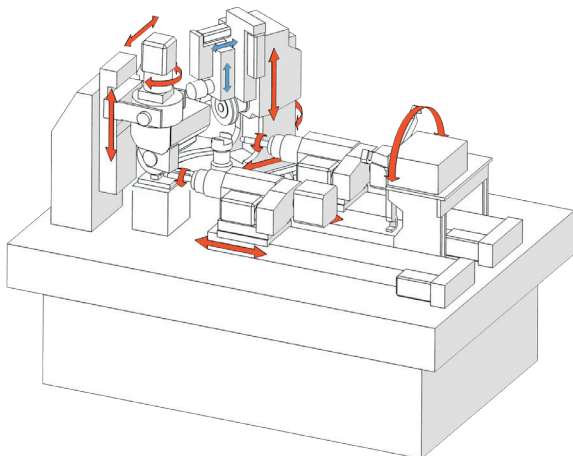

Fast loader

Ultra low workpiece changing time

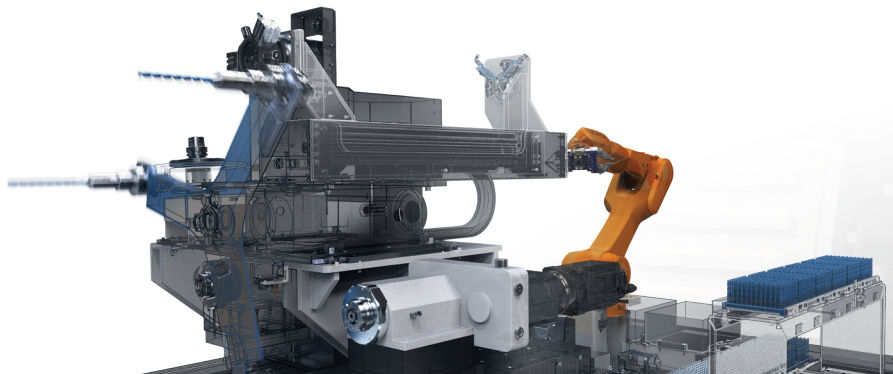

The 3-Arm Fast Loader moves the fluted workpiece from station 1 to station 2 for point or face grinding, unloads the finished workpiece and loads a new blank - all in one fast continuous movement!



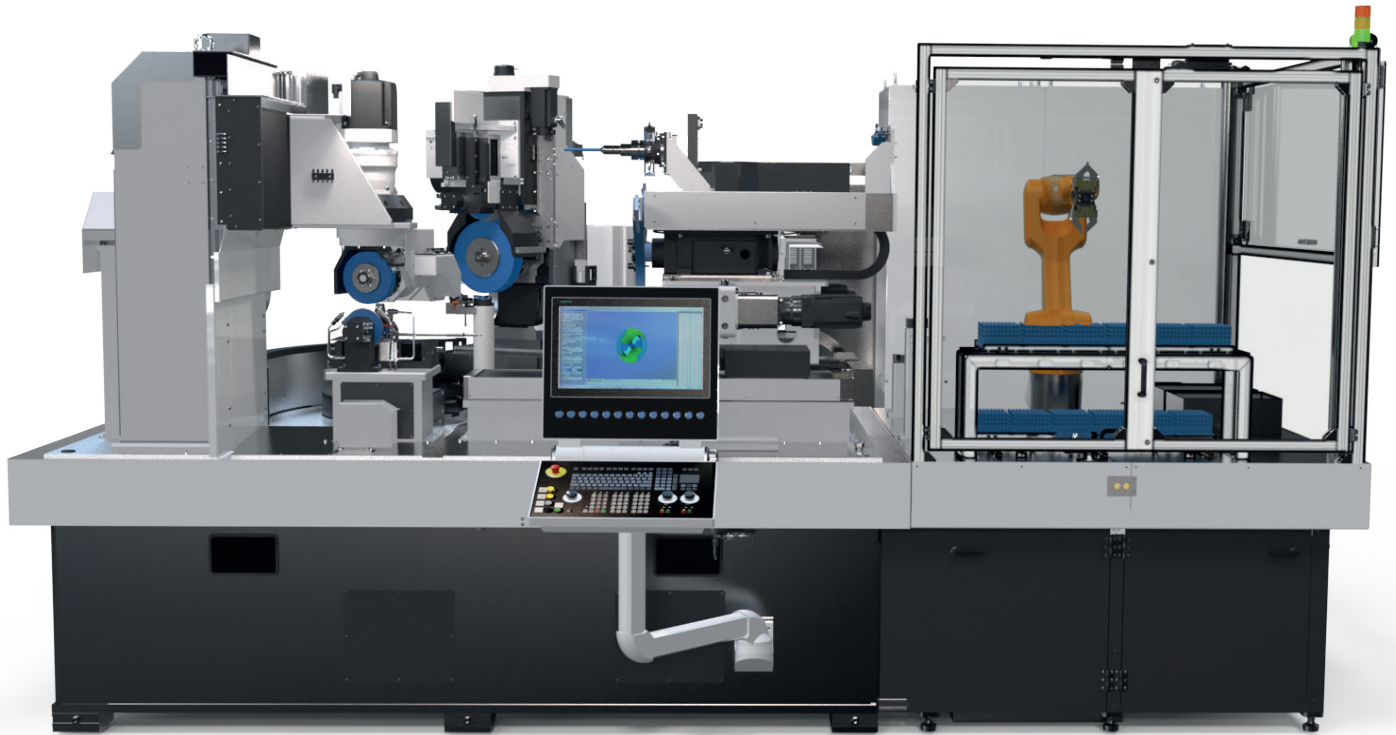

Multi Station Multi Operation

Production on two grinding stations for flute, OD and face grinding working simultaneously with a high end automated tool changing system.



Layout

Parallel operation of both grinding stations and tool changing system leads to superior cycle times and high production output.

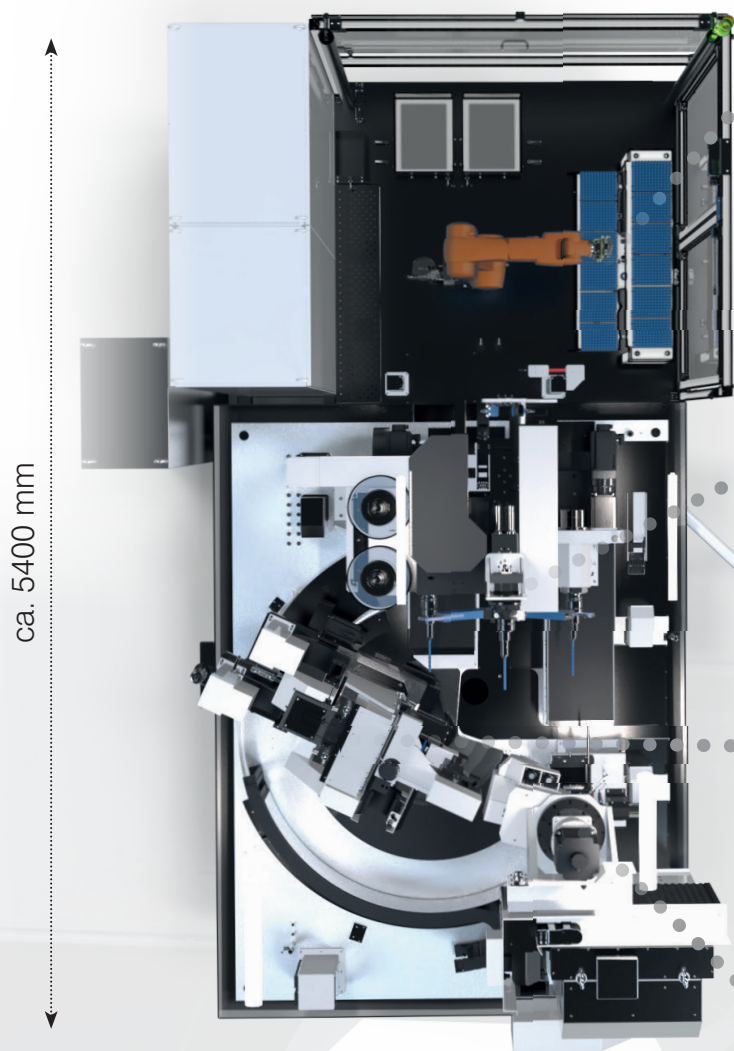

ca. 5400 mm

ca. 3000 mm

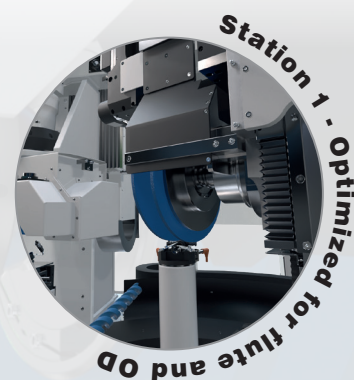
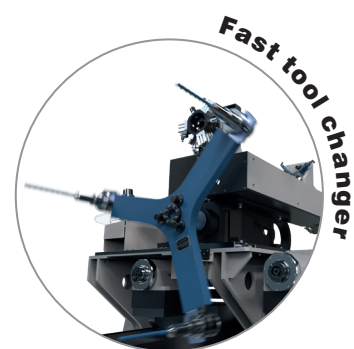
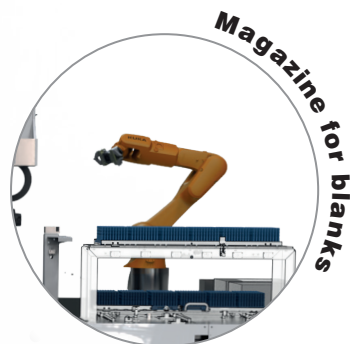

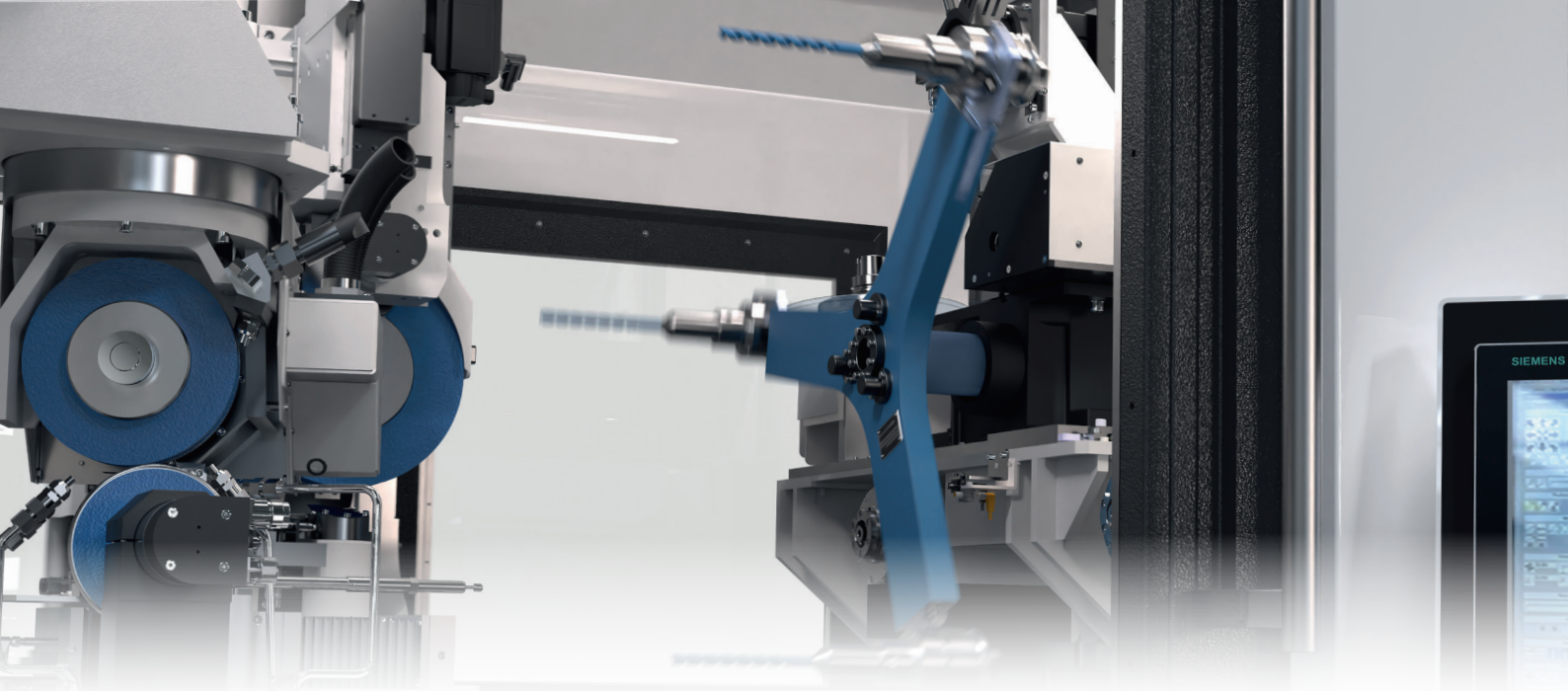

Machine Configuration

Elevate performance to the next level

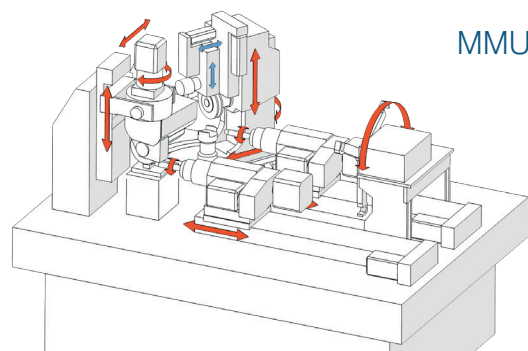

MMU

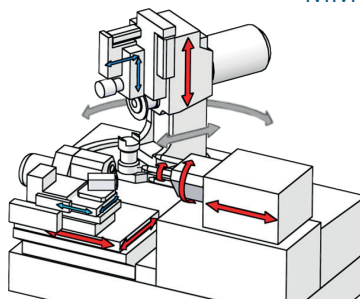

MMW

HAUX Modules expand the scope of our machines and give you the choice in what kind of machine you will get. HAUX Universal grinding machines offer outstanding performance and speed with high flexibility. Decades of know-how of the pioneers of high speed grinding made its way into our new line ups.

The Modular Multi includes the best of our UE-Line as well as an optimized flute and OD grinding station combined with high end cnc dressers and a top of the line automation solution.



Modules

The base configuration of the MM can be expanded using HAUX Modules

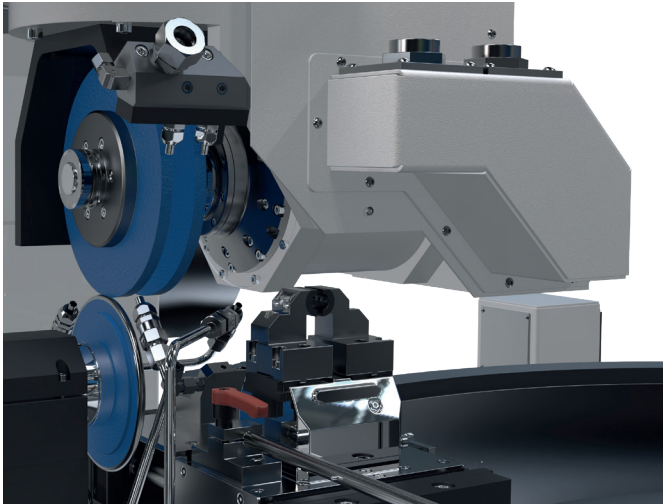

Workpiece support

Hydraulic or servo driven

The standard workpiece support is optimized for fast face grinding. Two halves of a bushing perfectly spread the grinding forces and hold the workpiece in place.

Modules

Customization using existing solutions

Expansions like measuring probes or ID-grinding spindles are available for station 2 that is based on our UE-Line.

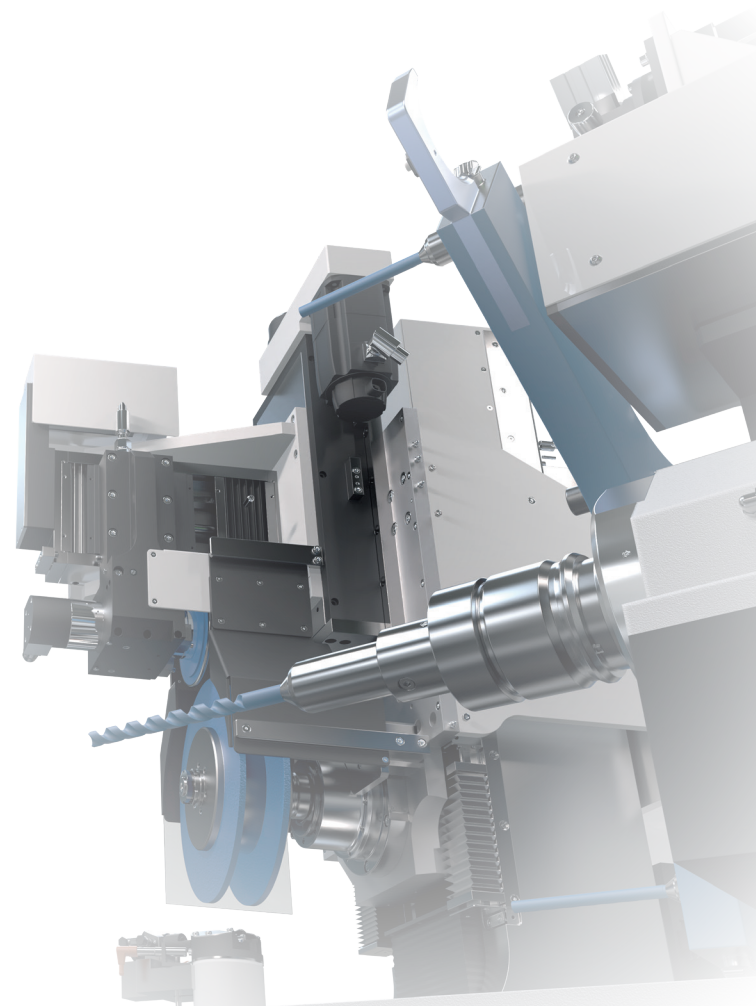
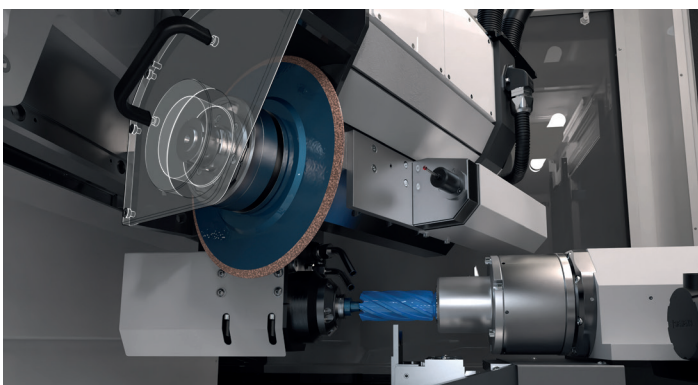

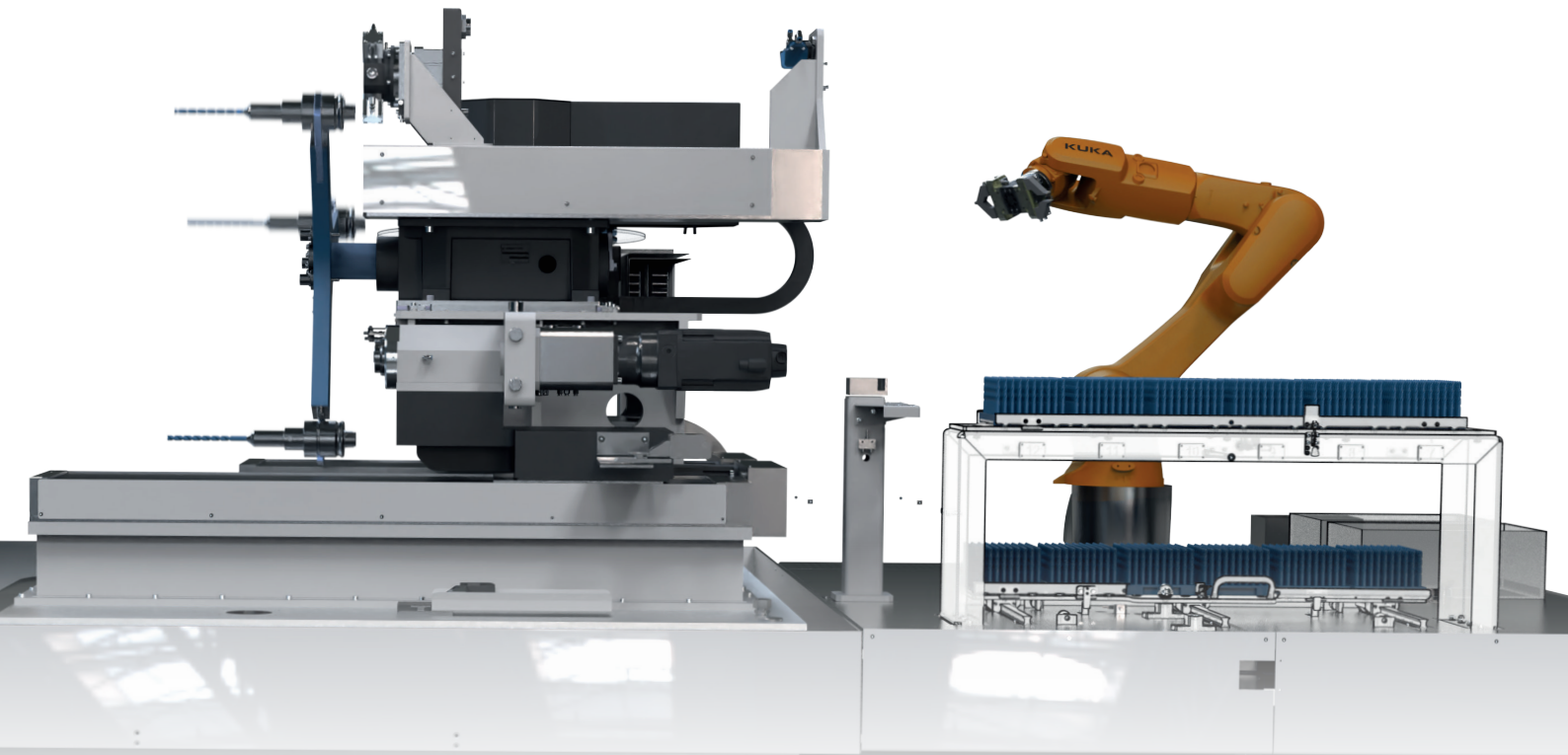

HAUX

Automation

Elevate performance to the next level

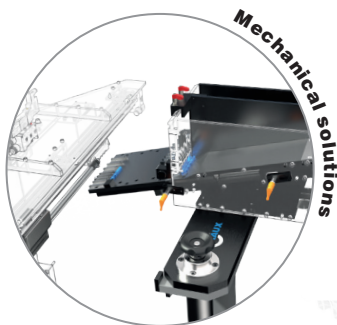

Mechanical solutions

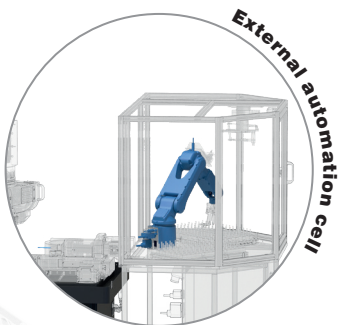

External automation cell



Integrated automation cell



Special solutions



Robot out

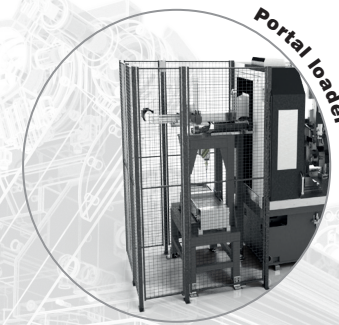

Portal loader



Portal connecting machines

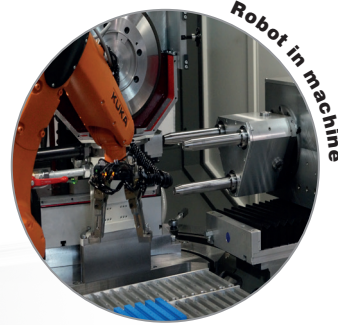

Robot in machine



HAUX offers the right automation solution for every situation.

Software

Modular - Expandable - Integrated

Our modular software runs on single machines as well as multi station machines or machines integrated in manufacturing cells. It allows integration into your company's network. Part, order, tooling or measurement data is easily exchanged. Autonomous operation of our machines is optional.

HAUX uses its own software on NC- and PLC-level and cooperates with MTS Switzerland for special use cases. HAUX own profiling software offers great value and specialized optimization for intended applications.

Remote access is offered by default and a new RED-box offers secure high volume data exchange and machine monitoring.

Applications

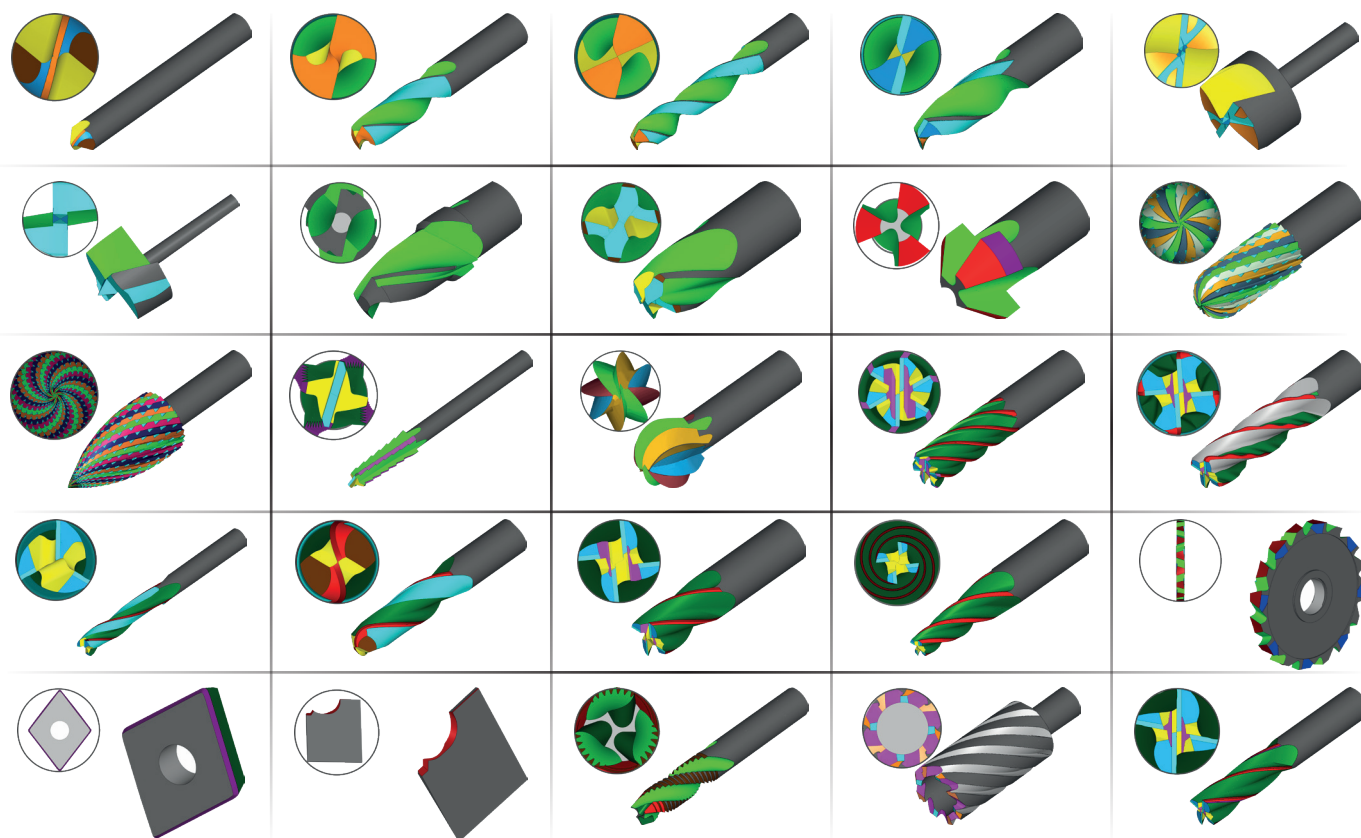

HAUX HMI

Individual UI - Preview / Simulation

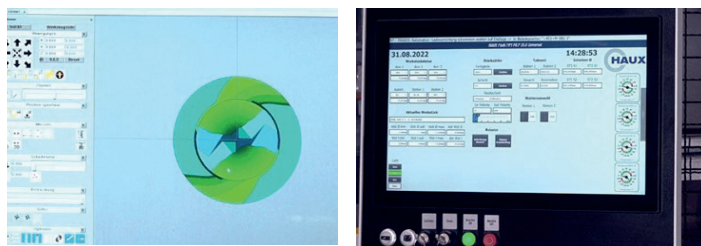

HAUX HMI with parametric tool definition includes live preview of each parameter's effect and on screen explanations.

Current process values are displayed during operation.

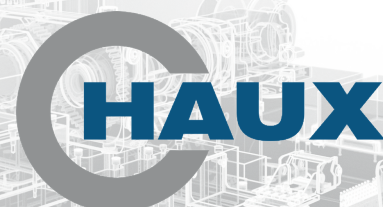



HAUX MOVING INNOVATION

For more information visit hauxmt.com or contact us for an individual consultation.

UE Line

Universal Eco - Modular Universal grinding

The UE-Line is our allround talent - flexible and expandable. The 5-Axis grinding kinematic of the base model offers you full flexibility and the extra strong structure of all components allows high speed and feed rates. Many different configurations are possible to specialize for specific production requirements using HAUX Modules.



UP Line

Universal Premium - High End Universal grinding

The HAUX UP-Line offers full autonomy and ultra high precision. Its high precision servo axis lead to a perfect surface finish and the the high end base body eliminates vibrations. The top model the UPT combines two stations with an automation cell inbetween. Collet changes, tool changes and even grinding wheel packet changes can be done fully automatic.



MM Line

High Performance Multi Station

The MM-Line combines two main grinding stations on one base body and offers excellent cycle times using a high end tool changing system that can move the tool between stations and load as well as unload in one single fast movement.



Special

High Performance Multi Station

HAUX has a lot of experience in special applications and individual engineering projects. For special use cases we work closely with our customer to develop the optimal machine for the specific use case.

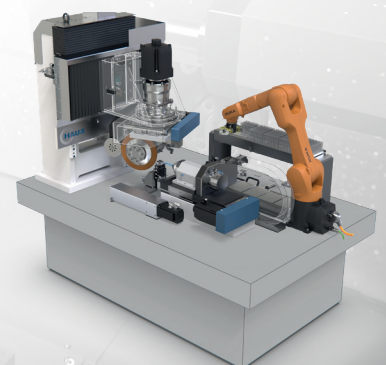



HAUX MOVING INNOVATION

HAUX Machine Tools offers decades of know-how and innovations of the pioneers of high speed grinding.

Contact

HAUX Machine Tools GmbH

Ebinger Str. 50
72510 Stetten a.k.M
Baden-Württemberg

GERMANY

Phone: +49 7573 95455-0
FAX: +49 7573 95455-30

Internet: hauxmt.com
E-mail: info@hauxgmbh.de

International

HAUX JAPAN Office
Phone: +49 6930 0646 20
E-Mail: m.westermann@hauxgmbh.de
Contact: Mr. Westermann

HAUX INDIA Office
411041 Pune
INDIA
Phone: +91 83081 06677
E-Mail: m.deshpande@hauxgmbh.de
Contact: Mr. Deshpande

HAUX RUSSIA / BELARUS /
KAZAKHSTAN Office
ATE Tools GmbH
Phone: +49 7433 908949 20
E-Mail: a.teichert@hauxgmbh.de
Contact: Mr. Teichert

HAUX FRANCE Office
Phone: +49 7435 8251
E-Mail: m.maisch@hauxgmbh.de
Contact: Mrs. Maisch



For more Information visit
HAUXMT.com